

Integrated and Separate Type In Situ Zirconia Oxygen/ High Temperature Humidity Analyzer ZR202/ZR402/ZR22



ZR202/ZR402/ZR22

EXxt *Integrated and Separate Type In Situ Zirconia Oxygen/
High Temperature Humidity Analyzer*

Distribué par :



2 rue René Laennec 51500 Taissy France
Fax: 03 26 85 19 08, Tel : 03 26 82 49 29

Email : hvssystem@hvssystem.com
Site web : www.hvssystem.com

Yokogawa presents zirconia oxygen analyzers for saving energy and environmental protection

Get a Long Service Life and Stable Operation with a Zirconia Sensor Sensor Replacement is Easy

- A molecular bonding method completes installation of platinum electrodes, and its inherent connection prevents separation of platinum from the zirconia element
- A lead-less electrode design eliminates electrical disconnection
- Special coating protects the platinum and prevents the sensors from deteriorating or becoming damaged
- No special tool is required for cell replacement. Whenever required, the cell is easily removed by removing four screws from the top of the probe. Down time ("from the time installation is started until it is completed") is minimized to approximately ten minutes. After the cell is replaced, the analyzer requires a zero and span calibration only once

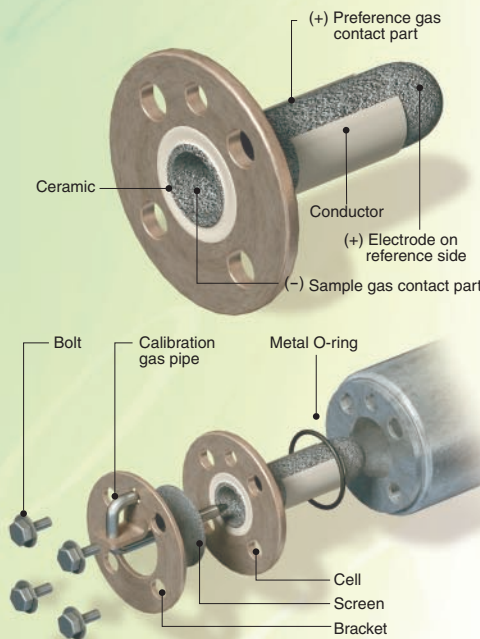

Principle of Zirconia Oxygen Analyzer

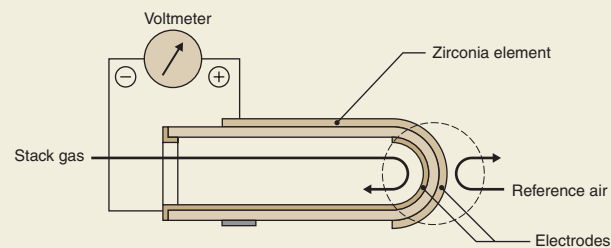

The principle of the zirconia oxygen analyzer is as follows:
At high temperatures the zirconia element, as a solid electrolyte, is a conductor of oxygen ions. Platinum electrodes are attached to the interior and exterior of the zirconia. Heating the element allows different partial oxygen concentrations of gasses to come into contact with the opposite side of the zirconia creating an oxygen concentration cell. In other words, oxygen molecules gain electrons to form oxygen ions with higher partial oxygen concentrations. These ions travel through the zirconia element to the other electrode. At that point, electrons are released to form oxygen molecules (refer to the chemical formula). The Nernst expression can be applied to calculate the force by measuring the electromotive force E generated between the two electrodes.

Electrode with high oxygen partial pressure: $O_2 + 4e \rightarrow 2O^{2-}$ (Reference side)
Electrode with low oxygen partial pressure: $2O^{2-} \rightarrow O_2 + 4e$ (Reference side)
Reactive electromotive force E(V) can be derived from Nernst's formula.

$$E = -\frac{RT}{nF} \ln \frac{P_x}{P_A}$$

R: Gas constant; T: Absolute temperature; n: 4; F: Faraday's constant;
Px: Oxygen partial pressure of zirconia element on the measuring gas side(%);
PA: Oxygen partial pressure of zirconia element on the reference air side(%);
Atmospheric air: 20.6(%); Instrument air: 21.0(%)

For the ZR22 cell, temperature is 750°C and the correspondingly reactive electromotive force E =

$$E = -50.74 \log \frac{P_x}{P_A} \text{ [mV]}$$

$$P_x = P_A \cdot 10^{\frac{E}{50.74}}$$

ZR202G/ZR202S

Integrated Type In Situ Zirconia Oxygen / High Temperature Humidity Analyzer

- Can cut wiring, piping and installation costs
- Can be operated in the field without opening the cover using an infrared switch
- Allows replacement of the zirconia cell and heater in the field
- Can measure either oxygen concentration or humidity with a single analyzer
- Remote maintenance using digital communication reduces maintenance cost.
- Explosionproof approval ATEX: EExd IIB + H₂, Group II, Category 2GD, T2, T300°C
FM/CSA: Class I, Division 1, Group B, C and D, Class II/III, Division 1, Group E, F and G, T2

Automatic Calibration Unit

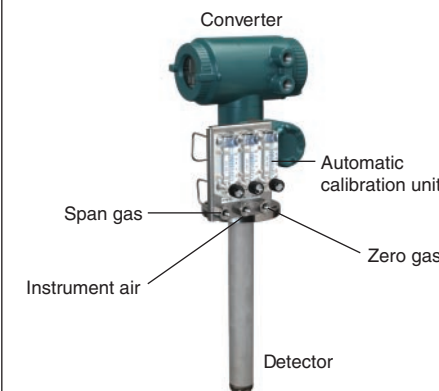

- The automatic calibration unit can be attached in the field easily



◀ ZR202G



Infrared switches enable operation without opening the display cover

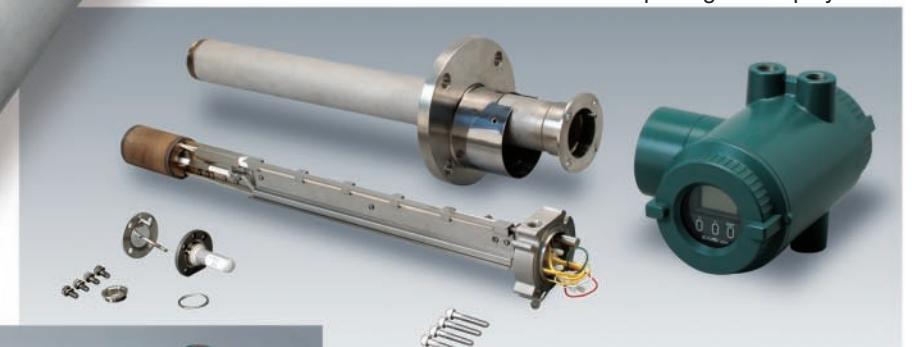

Heater assembly is easily replaced in the field



▲ ZR202S



ZR402G/ZR22G/ZR22S

Separate Type In Situ Zirconia Oxygen / High Temperature Humidity Analyzer

- Liquid-crystal touch panel display provides easy operation
- Interactive model displays instructions to follow, including those for: settings, oxygen concentration trends, and calibration operations
- Digital communications features are provided as standard – this enables the analyzer to be maintenance-serviced remotely
- Can measure either oxygen concentration or humidity with a single analyzer
- Highly reliable measurements with trend-data graphs
- The zirconia cell and heater assembly can be replaced in the field
- Explosionproof approval ATEX: EExd IIB + H₂, Group II, Category 2GD, T2, T300°C
FM/CSA: Class I, Division 1, Group B, C and D, Class II/III, Division 1, Group E, F and G, T2

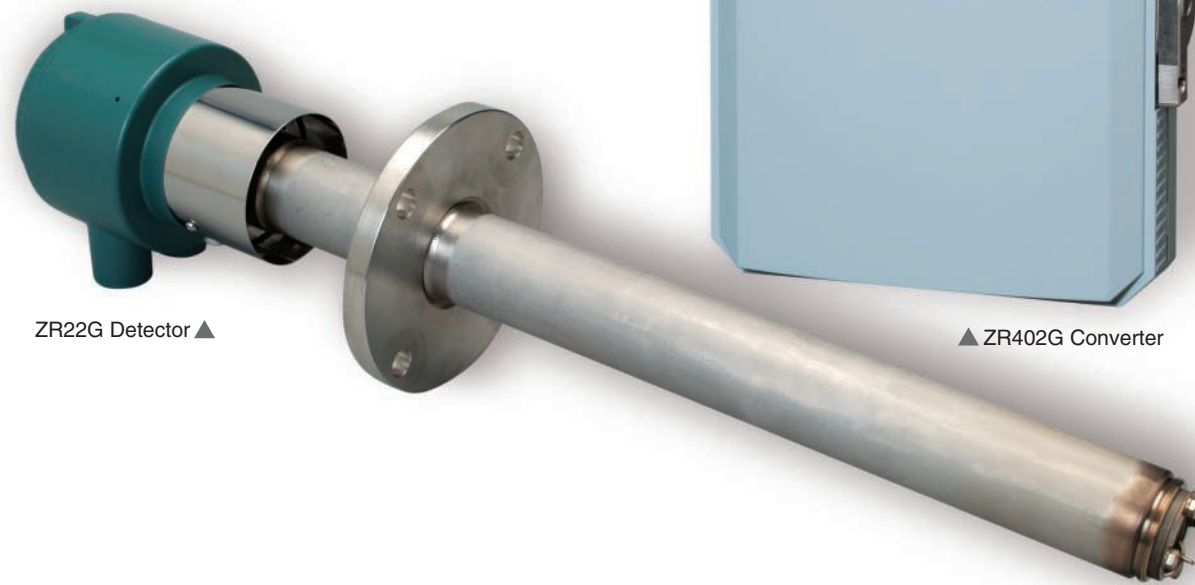

ZR22G Detector ▲

▲ ZR402G Converter

ZR402G Separate Type Converter

Complete Operation Display

- Interactive operations along with operation display
- A variety of display modes – enabling you to select the operation mode freely
- Back-lit LCD allows viewing even in the darkness
- Error codes and details of errors can be checked in the field without the need to refer to the appropriate instruction manual



Self-testing suggests countermeasures for problems

If a problem occurs, the liquid-crystal display will provide an error code and the reason for the problem. This enables prompt and appropriate corrective action to be taken.

Error code	Reason for error
E--1	Cell failure
E--2	Abnormal heater temperature
E--3	Defective A/D converter
E--4	Faulty EEPROM
ALARM1	Abnormal oxygen concentration
ALARM2	Abnormal moisture content
ALARM3	Abnormal mixing ratio
ALARM6	Abnormal zero calibration factor
ALARM7	Abnormal span calibration factor
ALARM8	Stabilization time over

Typical Converter Displays

● Example of basic display

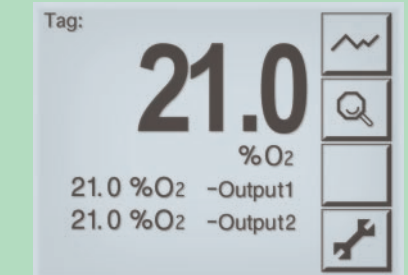

This display enables you to operate the analyzer while checking data on the display.

● Example of trend display – displays data changes

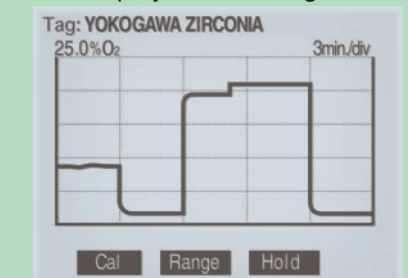

During automatic calibration, you can check stabilized display data while viewing oxygen trend data, thus providing highly reliable calibration.

● Example of setting data display – displays data changes

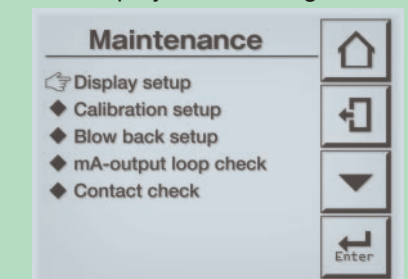

- One-touch interactive display operation
- User-friendly design providing easy operation without having to use the instruction manual.

Achieving accurate O₂ measurement in exhaust gas

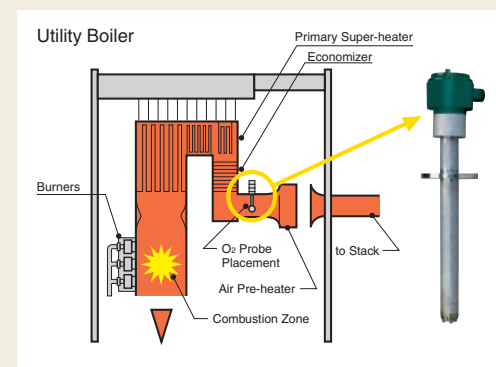

With the measurement of oxygen in the exhaust gas the flow of fuel can be controlled for optimum burner efficiency and minimum environmental effects.

The relationship between air Rates and Heat Efficiency

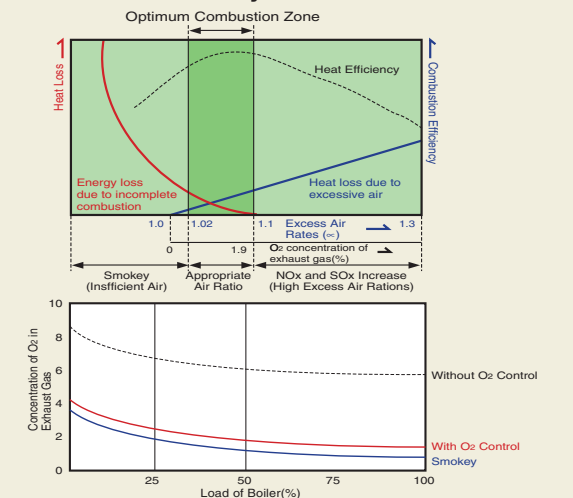

ZR22S Explosionproof version Detector

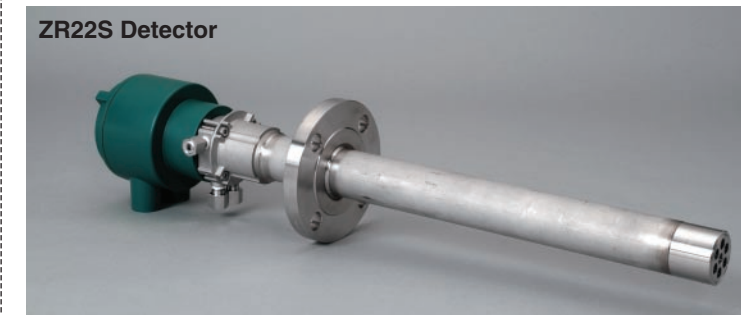

System configuration

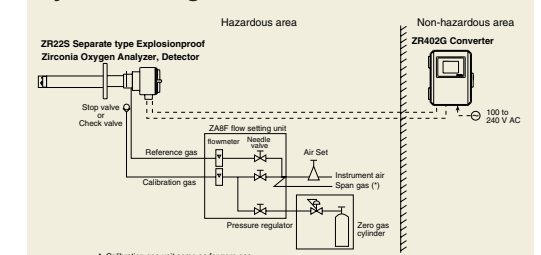

Application and System Configuration

The basic configuration consists of a probe and a converter. A flow unit and calibration cylinder may be added as required, depending on the application requirements. The optimal probe may be selected from a variety of probes. One type of converter is capable of handling all applications.

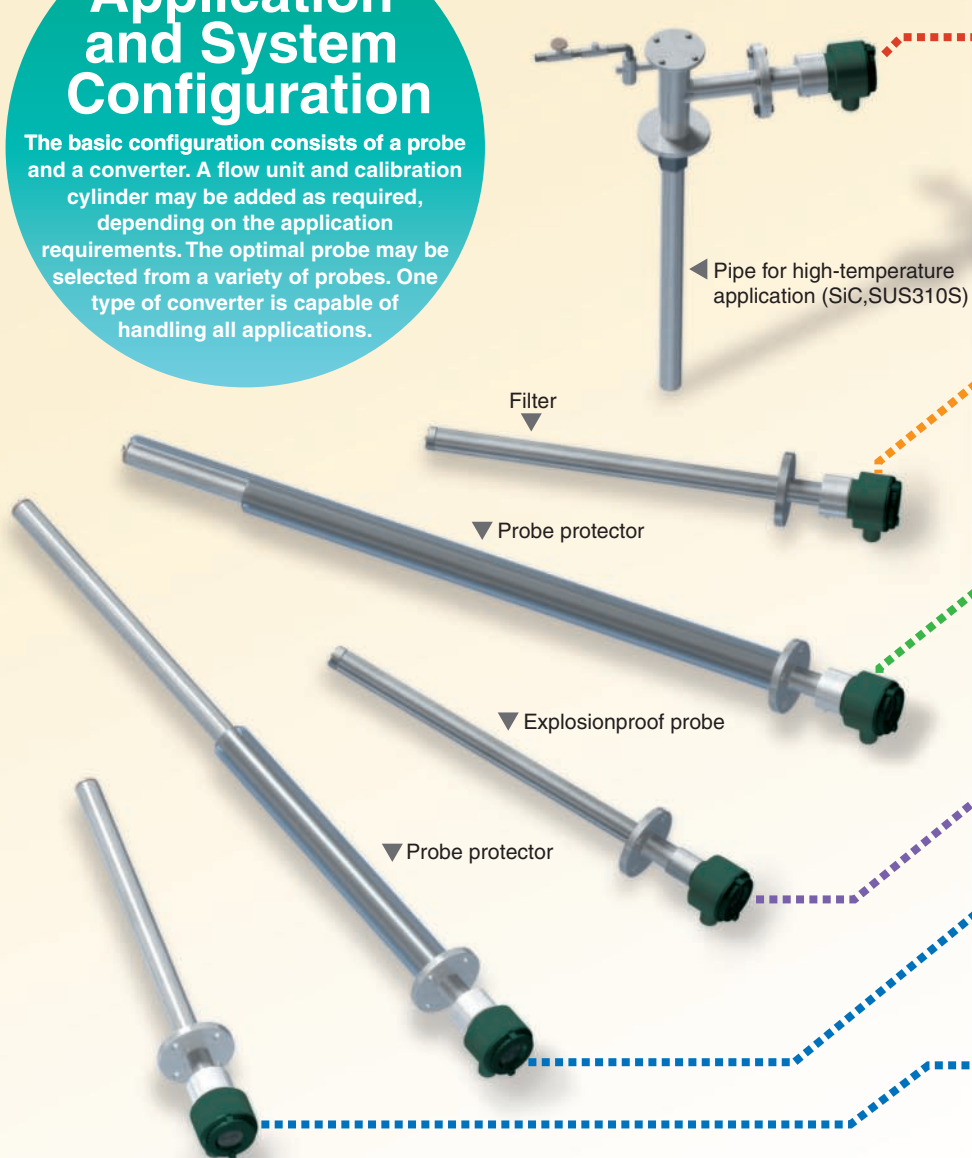

Detector

High temperature probe (0 to 1400°C)

For sample gas temperature over 700°C

General purpose probe + filter

Protects probe against dust

General purpose probe + probe protector

Protectors prevent the probe from being eroded by fine particles

Explosion proof probe

General purpose probe + probe supporter

Protectors allow the probe to be installed horizontally

General purpose probe (0 to 700°C)

Various insertion lengths are available: 0.4, 0.7, 1.0, 1.5, 2.0, 2.5 and 3.0 meters

Application

Boiler (fuel oil and gas)	Common
Boiler (coal)(pulverized coal on fluidized bed)	
Boiler (bark or wood chips)	
Heating furnace	Iron & steel
Soaking pit	
Annealing furnace	
Hot stove	Non-ferrous metals
Coke oven	
Sintering furnace	
Melting furnace	Ceramics
Heating and annealing furnaces	
Lime kiln (rotary)	
Lime kiln (vertical)	Ceramics
Cement kiln (cyclone exit)	
Glass melting furnace (in furnace)	
Glass melting furnace (in stack)	Ceramics
Ceramic baking furnace	
Heating furnace	
Naphtha cracking furnace	Petrochemical
Heating furnace	Pulp & paper
Black liquor recovery boiler	
Sludge kiln/boiler	
Forging furnace	Machinery
Heat treatment furnace	
Window box	
Drying furnace	Others
Reaction furnace	
Roasting furnace	
Incinerator	
Sludge burning furnace	
Fermentation tank	
Indoor oxygen-deficiency monitoring	

Signal line/heater line
Special cables not required. General-purpose shielded cables can be used. The distance between the probe and converter can be approximately 500 m if a 2 mm² cable is used and approximately 300 m if a 1.25 mm² cable is used.

Calibration gas line
Check valve installed to prevent a reverse flow of the process gas.

Converter

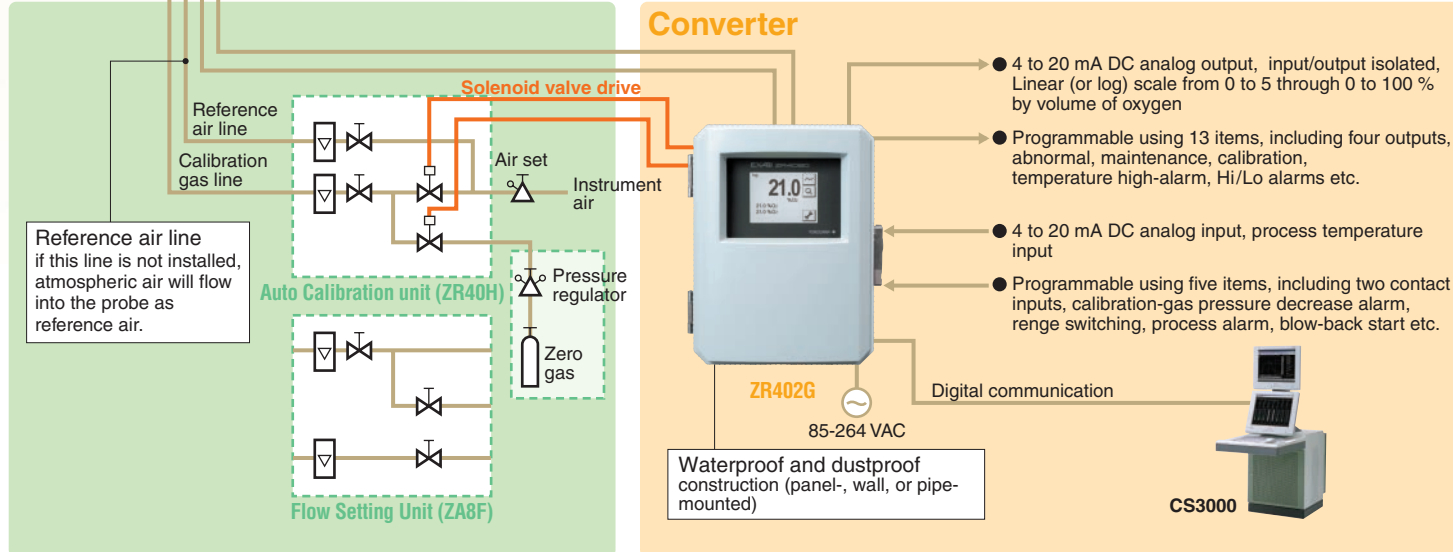

- 4 to 20 mA DC analog output, input/output isolated, Linear (or log) scale from 0 to 5 through 0 to 100 % by volume of oxygen
- Programmable using 13 items, including four outputs, abnormal, maintenance, calibration, temperature high-alarm, Hi/Lo alarms etc.
- 4 to 20 mA DC analog input, process temperature input
- Programmable using five items, including two contact inputs, calibration-gas pressure decrease alarm, range switching, process alarm, blow-back start etc.

Waterproof and dustproof construction (panel-, wall, or pipe-mounted)

CS3000

Probe for high temperature use (process temperature of 0 to 1400°C)

If the process temperature exceeds 700°C, use the probe for high-temperature application. For other special application requirements, appropriate probes and associated attachments are available.

Air Ejector

Process gas is ejected when the pressure is positive

Pipe

SiC(Silicon Carbide max. 1400°C) and SUS310S(Stainless steel max. 800°C) available. Insertion length 1.0m, 1.5m

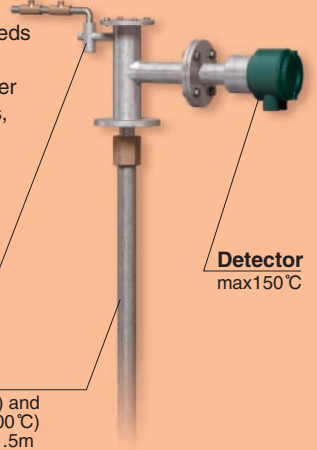

Application 1 Example of boiler instrumentation

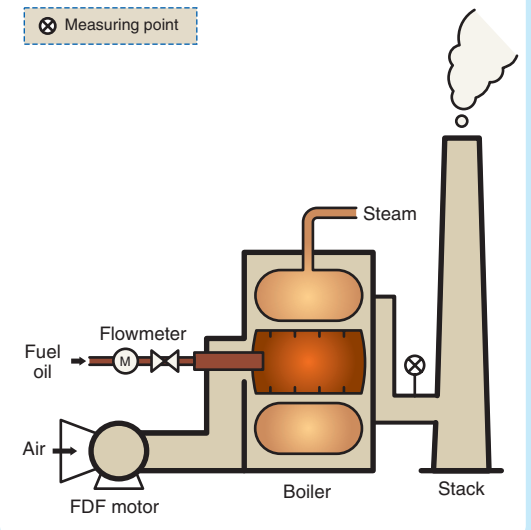

Application 2 Petroleum refinery process fired heater

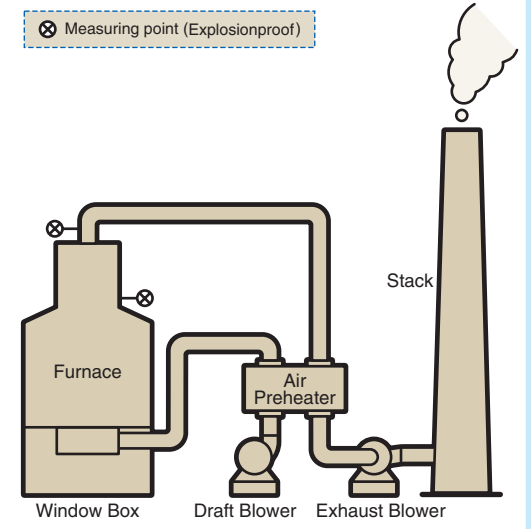

Application 3 paper machine drying process

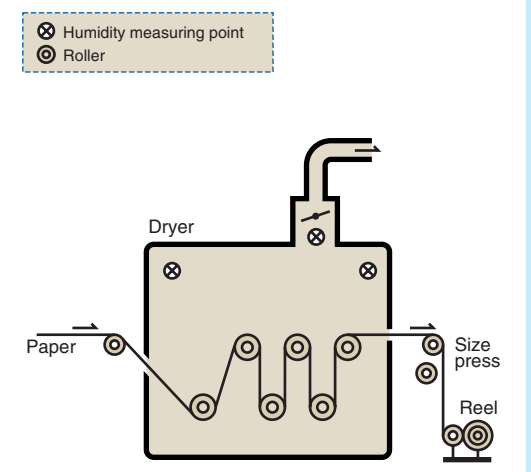

A Yokogawa Commitment to Industry

vigilance[®]

quality

innovation

foresight

What does Yokogawa **vigilance** mean to the future of your business? **Quality**. Through products that are built from the ground up and tested to the last hour, you're ensured continuous operation and more uptime. **Innovation**. Your business will benefit from new insights and capabilities, bringing true predictability to your process. **Foresight**. As the market changes, you'll have solutions that give you the continuity and flexibility to plan ahead and grow. Our partners know the difference. With Yokogawa, you can count on a lifetime of plant efficiency, from instrumentation to operation support. Let us be vigilant about your business.

YOKOGAWA ELECTRIC CORPORATION
World Headquarters

9-32, Nakacho 2-chome, Musashino-shi,
Tokyo 180-8750, JAPAN
Tel.: +81-422-52-5617 Fax.: +81-422-52-3421

World Sales Headquarters

9-32, Nakacho 2-chome, Musashino-shi,
Tokyo 180-8750, JAPAN
Tel.: +81-422-52-6339 Fax.: +81-422-52-6552

YOKOGAWA ELECTRIC ASIA PTE. LTD.

5 Bedok South Road, Singapore 469270.
Tel.: (65)2419933 Fax.: (65)2419919

YOKOGAWA EUROPE B.V.

P.O.Box 163,3800 AD Amersfoort,
Vanadiumweg 11, 3812 PX Amersfoort,
THE NETHERLANDS
Tel.: +31-33-4-641611 Fax.: +31-33-4-641610

YOKOGAWA CORPORATION OF AMERICA

2 Dart Road
Newnan, GA 30265-1040, U.S.A.
Tel.: +1-770-254-0400 Fax.: +1-770-254-0928

YOKOGAWA AMERICA DO SUL S.A.

Avenida Jurua, 149 Alphaville CEP 06455-010 Barueri
Sao Paulo BRAZIL
Tel.: +55-11-7295-6282 Fax.: +55-11-421-3538

Represented by: