

# Digital Indicating Controllers

## SELECTION GUIDE

Indicating Controllers	UT130/150/321/351/420/450/520/551/750
Process Controller	US1000
Program Controllers	UP150/351/550/750
Indicators with Alarms	UM331/351
Manual Setters	UD310/320/351



Distribué par :

Bulletin 05A01A01-01E



2 rue René Laennec 51500 Taissy France  
 Fax: 03 26 85 19 08, Tel : 03 26 82 49 29

Email : hvssystem@hvssystem.com  
 Site web : www.hvssystem.com

# A Complete Range of Exceptional Controllers

Select the One Suitable for Your Needs from YOKOGAWA Digital Indicating Controllers

96 × 96  
(1/4DIN)



**UP351** Active Display  
Program Controller  
with Active Color PV Display



**UP550**  
Program Controller



**UP750**  
Program Controller



**UM351** Active Display  
Indicator with Alarms  
with Active Color PV Display



**UT351** Ethernet Active Display  
Indicating Controller  
with Ethernet  
& Active Color PV Display



**UT450**  
Indicating Controller



**UT551** Ethernet Active Display  
Indicating Controller  
with Ethernet  
& Active Color PV Display



**UT750**  
Indicating Controller



**US1000**  
Process Controller  
(72×144mm)

48 × 96  
(1/8DIN)



**UM331** Active Display  
Indicator with Alarms  
with Active Color PV Display



**UT321** Active Display  
Indicating Controller  
with Active Color PV Display



**UT420**  
Indicating Controller



**UT520**  
Indicating Controller



**LL100,LL1100**  
Parameters Setting Tool

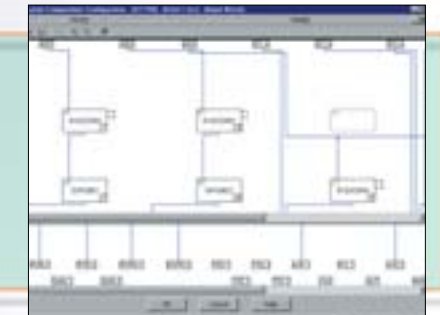

**LL200,LL1200**  
Custom Computation  
Building Tool

48 × 48  
(1/16DIN)



**UT130**  
Indicating Controller



**UT150**  
Indicating Controller



**UP150**  
Program Controller

(Unit:mm)

## For industrial furnace control

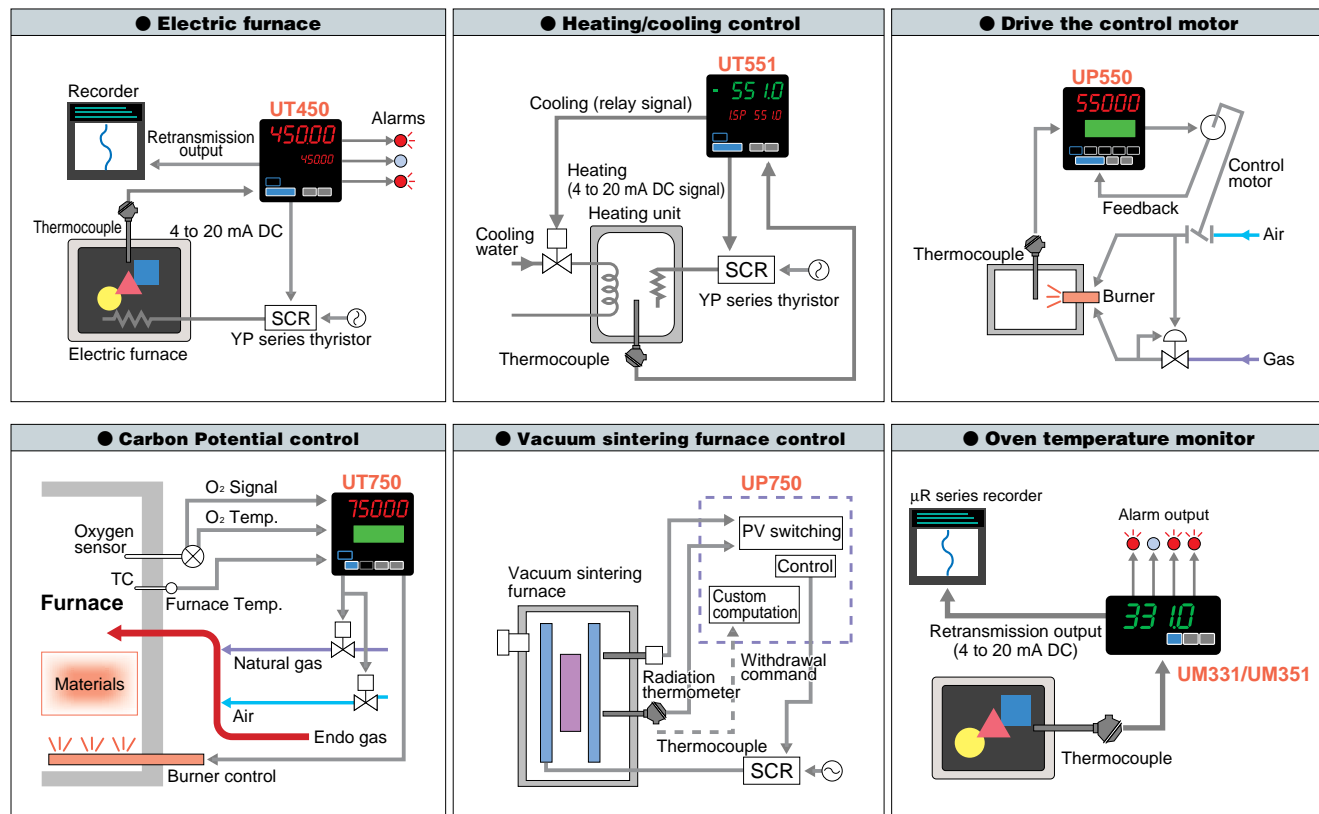

## For food and pharmaceutical industries

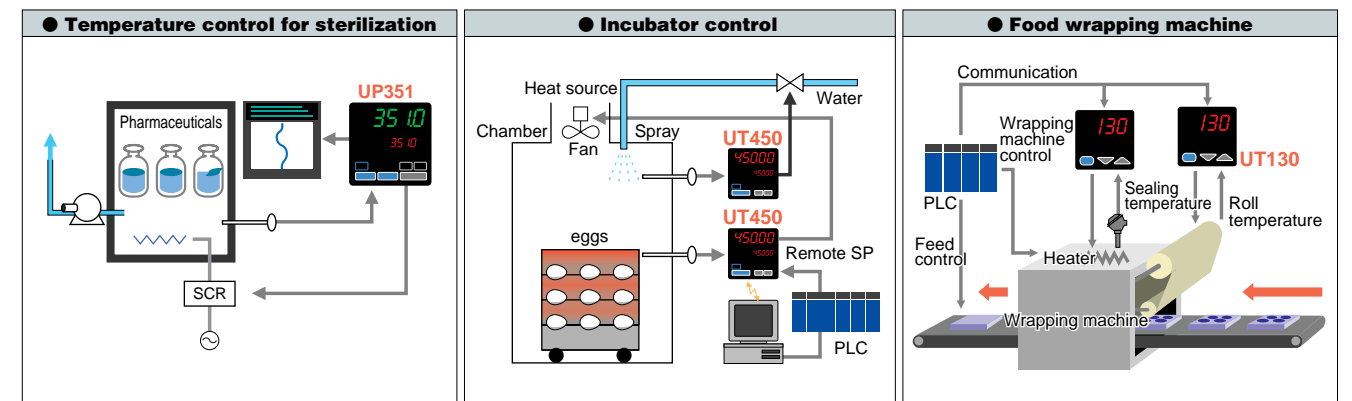

## Optimum PLC controllers for process control

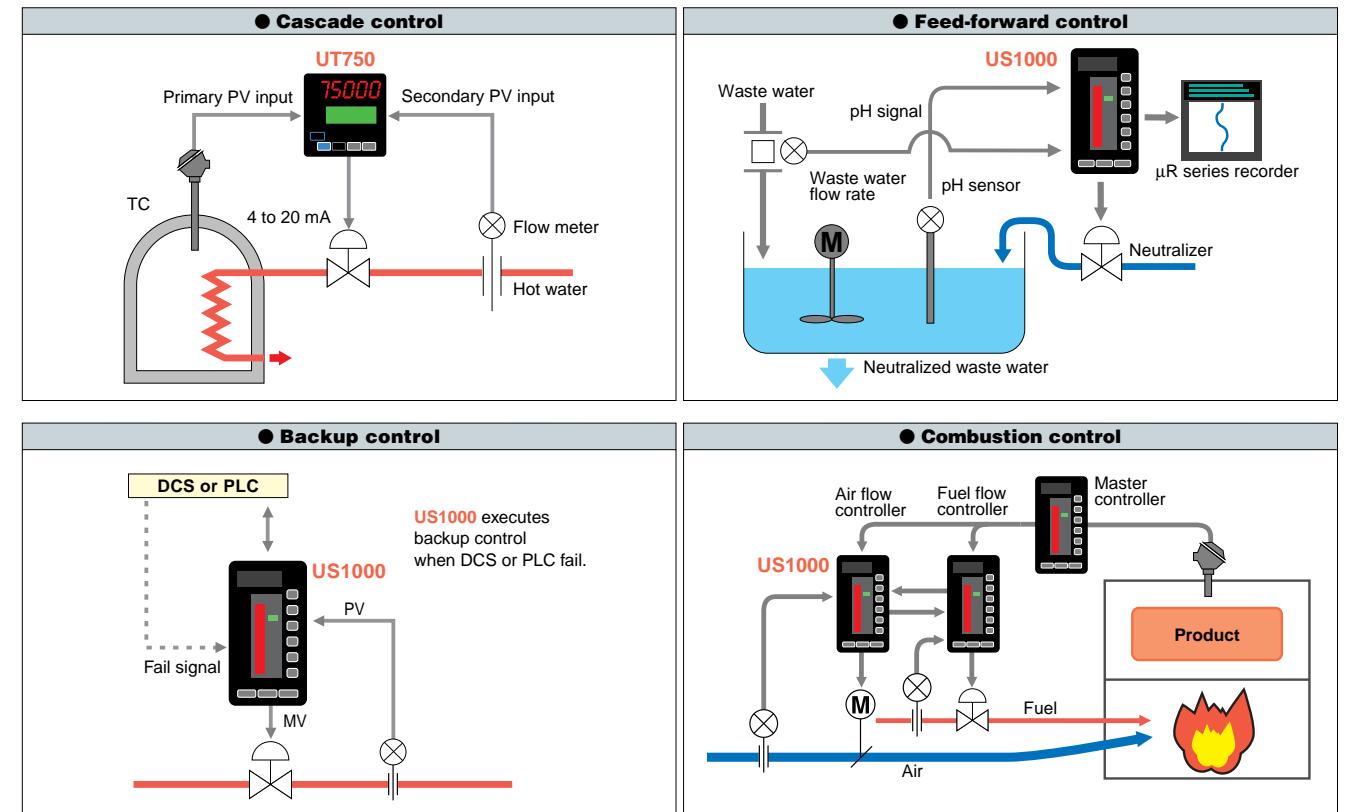

## For plastics processing and forming

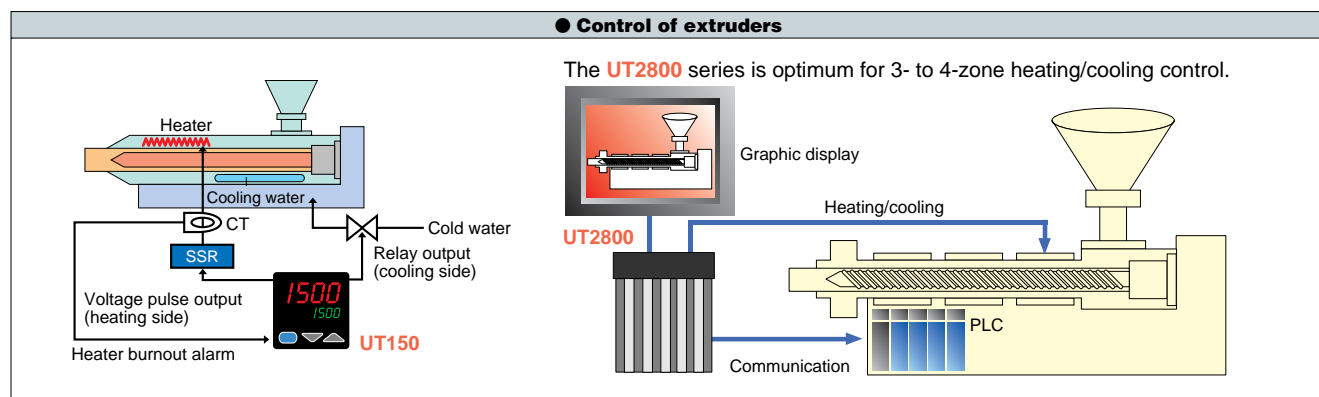

## For environmental testing and control

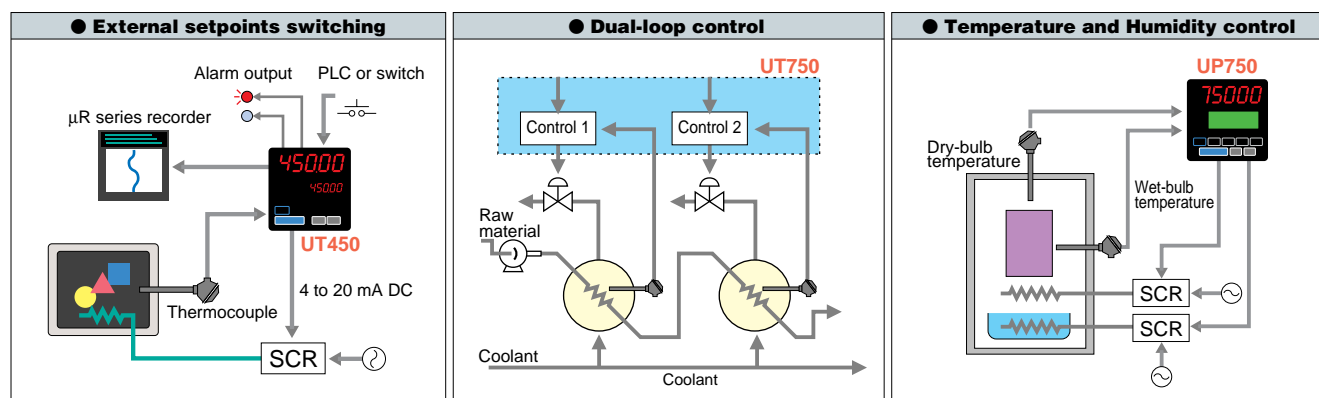

## For electronics and semiconductor manufacturing

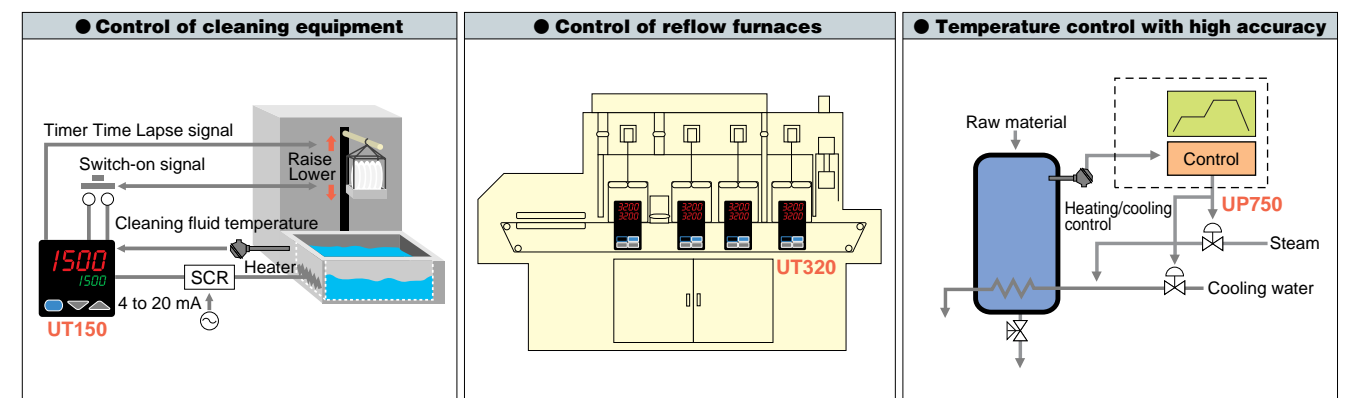

# Enhancing automation and process connectivity!

## ● Plug & Play Operation

- **ETHERNET-based architecture** allows new processes to be added as easily. –No need for extensive hardware to connect and run the application, because all information is managed on the server.
- Works with any **Modbus TCP/IP** compliant software. MODBUS function codes 03,06,08 & 16 are available.
- **Reduce labor cost in wiring and setup** of communications network.
- **Faster connection speed.**

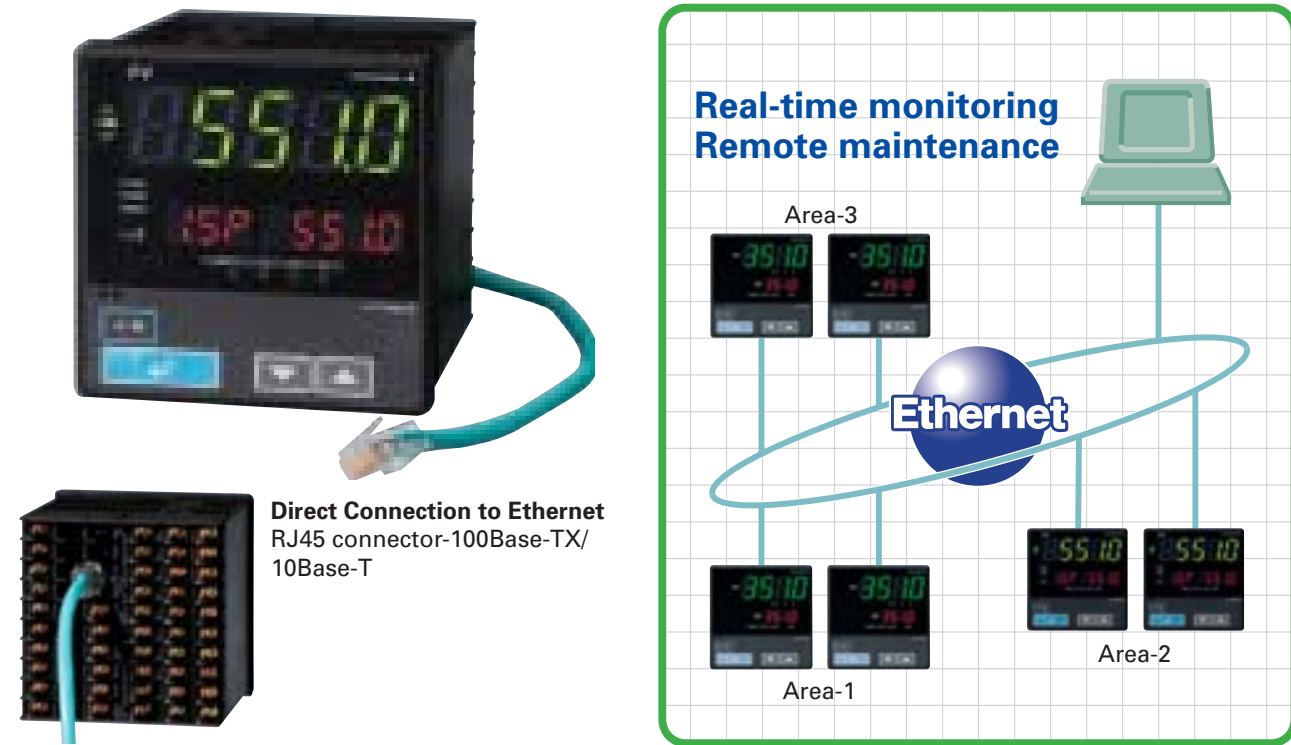

## ● Universal Input

- **Selectable among TC, RTD, mV and DC voltage.**

The type of input signal and input range can be changed at the customer side by some key operation or by using LL100 or LL1100 parameter setting tool.

Thermocouple Type	: K, J, T, B, S, R, N, E, L, U, W, PL-2, PR20-40, W97Re3-W75Re25
RTD Type	: Pt100, JPt100
DC Voltage Input	: 0.4 to 2V, 1 to 5V, 0 to 2V, 0 to 10V, 0.00 to 1.25V(Note), -10 to 20mV, 0 to 100mV

Note: For universal input 2 of UT420,UT450,UT520,UT550,UT750,UP550,UP750 and US1000 only.

- **0.1% Indication Accuracy.**
- **Models UT750, UP750 and US1000 have two universal inputs.**
- **Connectable up to two 2-wire transmitters simultaneously.**

All GREEN SERIES instruments have a 15V Loop Power Supply (15V LPS) for a transmitter. Moreover, 24V LPS is also available simultaneously for some instruments as optional function. Model US1000 has two 24V LPS functions. Applicable models for 24V LPS: UT321/351, UT450, UT550, UM331/351, US1000

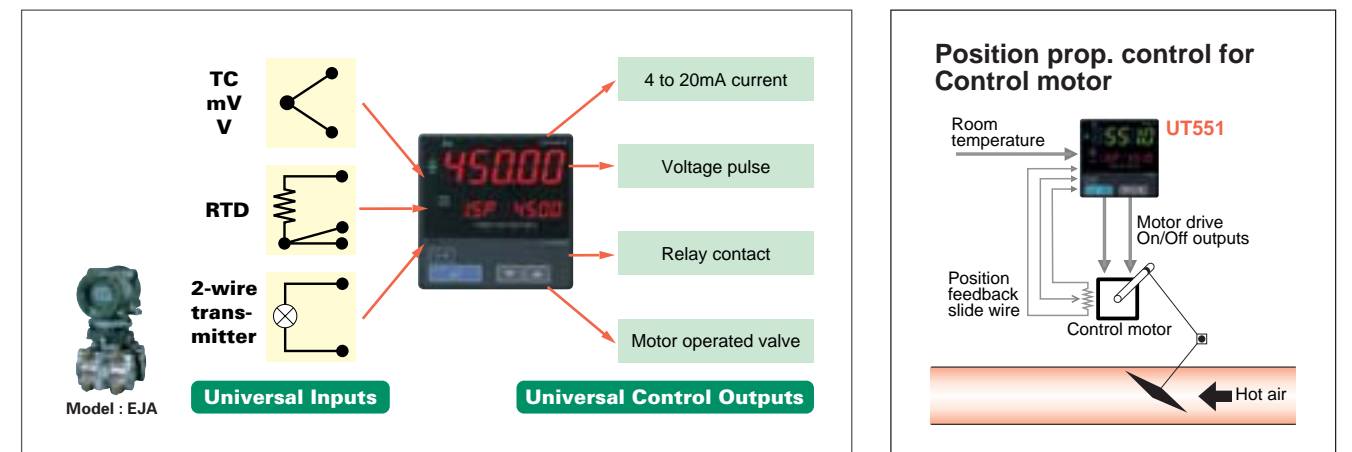

## ● Universal Output

- **Selectable among Relay, Voltage Pulse and Current outputs.**

Relay output: ON/OFF control, Time-proportional PID control

Voltage Pulse output: Time-proportional PID control

Current output: Continuous PID control

- **Heating/Cooling Control has two sets of universal outputs.**

Any combinations with Relay, Pulse and Current outputs are available. There are some limitations to UT320/350 controllers.

- **Drive the Motorized Control Valve by using Position-Proportional PID.**

The position-proportional PID control function has two sets of relay outputs for direct / reverse rotation of motorized control valve.

The side wire input to feed back the valve position is also available.

## Simple Operation Fewer key strokes during normal operation

### ● Simple Key Operation

Setpoint (SP) can easily be changed: press the or key to display the required setpoint and then press the key to register it.(See the figure on the right.)

For a programmable controller, display the pattern signal and press the key to start the operation. Press the key to stop the operation.

### ● Security Functions with Password

A password can be set to prevent accidental or deliberate change to the setup parameter settings of the controller.

Applicable models:All the models of GREEN Series (except for UT130,UT150,UT152 and UT155)

Press the or key to display the required setpoint (SP).

Press the key to register the setpoint (SP).



## Controllers with Active Color PV Display

### See the status of your process conditions **INSTANTLY!**

- **Alarm Status**  
Active color display changes from **Green(normal)** to **Red(alarm)**
- **Deviation Status**  
Color changes based on a PV deviation from SP
- **User-defined Color**  
Choose between **Green** or **Red** display for constant readings

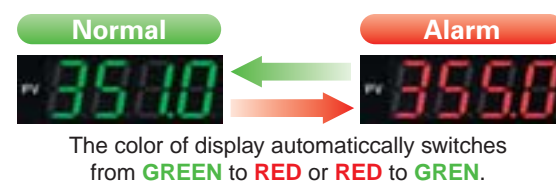

# Powerful Control Functions Various functions for freely creating input/output-related computations

## 14 types of build-in Controller Functions

**PV auto-selector**

**PV switching**

**Cascade control**

**Dual-loop control**

**Temperature & humidity control**

**Loop control for backup**

- Single-loop control
- Cascade primary-loop control
- Cascade secondary-loop control
- Cascade control
- Loop control for backup
- Loop control with PV switching
- Loop control with PV auto-selector
- Loop control with PV-hold function
- Dual-loop control
- Temperature & humidity control
- Cascade control with two universal inputs
- Loop control with PV switching and two universal inputs
- Loop control with PV auto-selector and two universal inputs
- Custom computation control

## SUPER Function suppresses overshooting

The field-proven **SUPER** function utilizes built-in operator experience and fuzzy theory to deliver fine control and suppress overshooting.

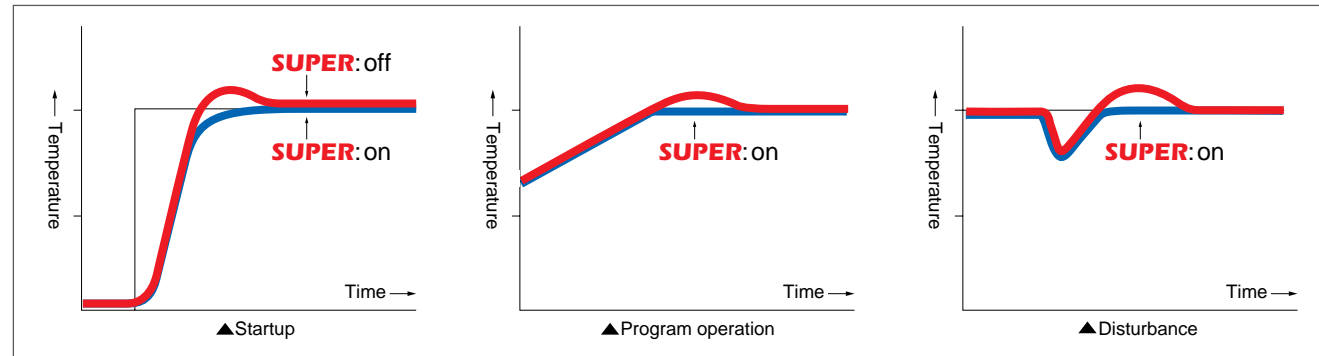

## SUPER 2 Function suppresses hunting

The new **SUPER 2** function utilizes built-in operator experience and modern control theory to deliver fine control and suppress hunting.

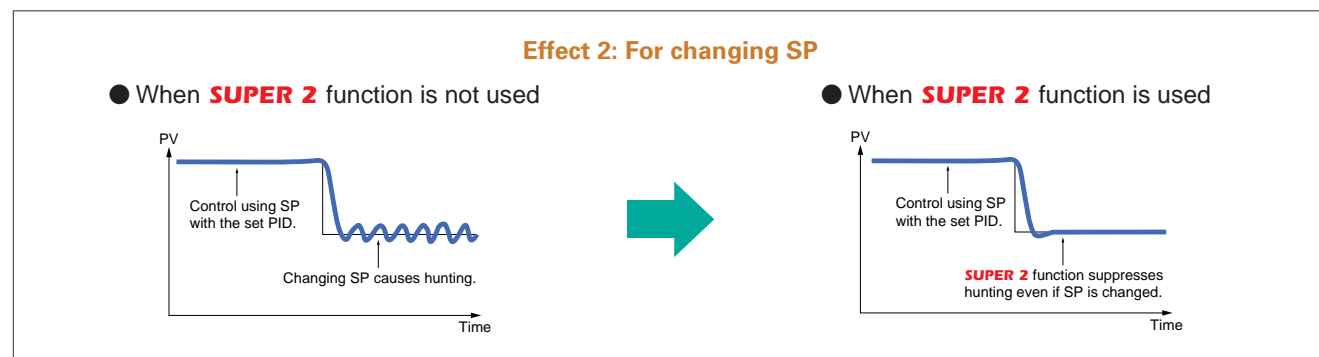
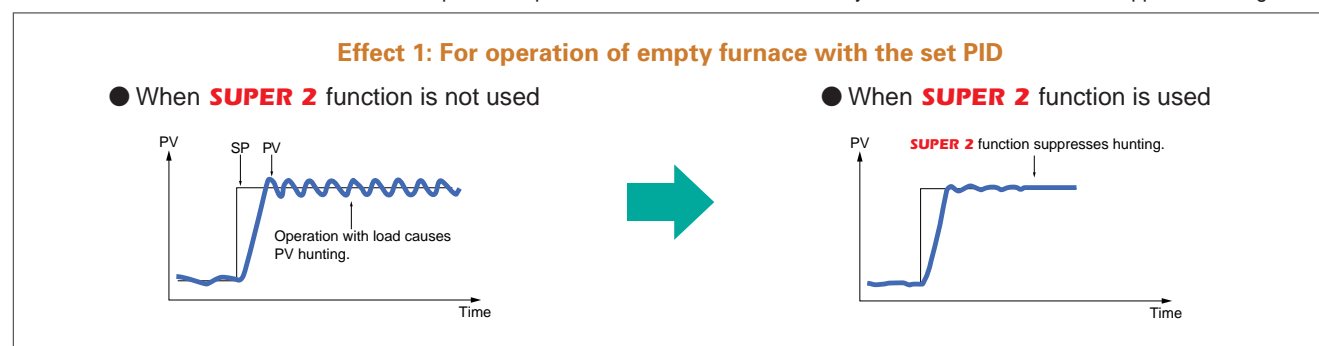

# Communication Functions

## MODBUS Communication

A protocol used for communicating with a general-purpose personal computer and PLC.

Protocol: MODBUS RTU  
MODBUS ASCII  
Baud Rate: 600bps to 38.4kbps  
(up to 9,600bps in case of MODBUS.)

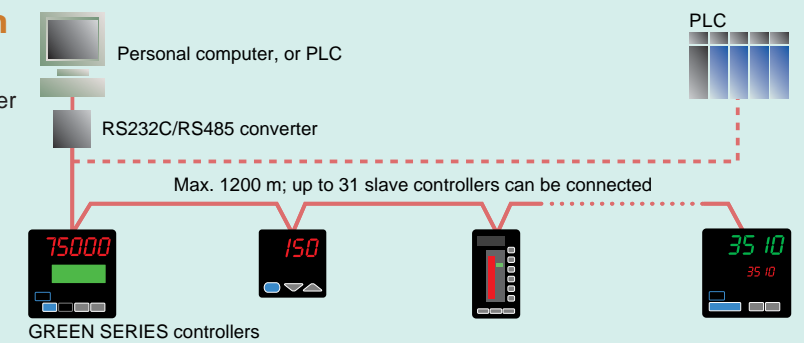

## CX communication

A CX1000/2000 lets you control external UT controllers with same ease as CX's embedded controls.

Connectable models : UT320, UT321, UT350, UT351, UT420, UT450, UT520, UT550, UT750

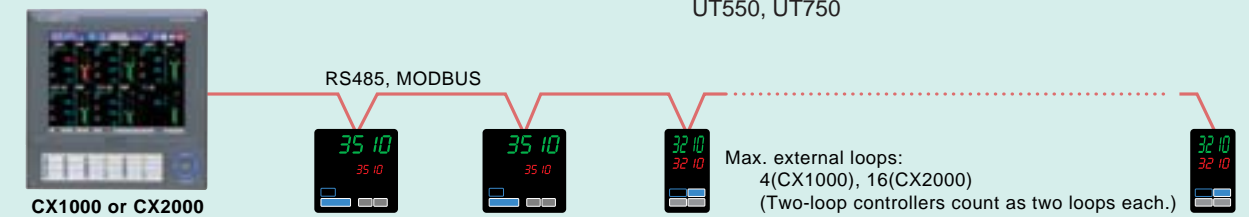

## Personal Computer Link Communication

A protocol used for communicating with a general-purpose personal computer, or UT link module and serial communication module of PLC (FA-M3 range-free controller).

FA-M3 and a recorder can be connected in the same line.

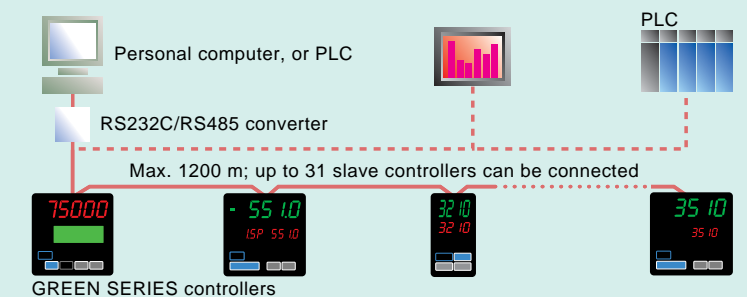

## Ladder Communication

A protocol used for communicating with a PLC. Communication with a computer link unit of the MELSEC-A series (made by Mitsubishi Electric Corporation) is possible.

(\*) FA-M3 is the PLC made by Yokogawa.

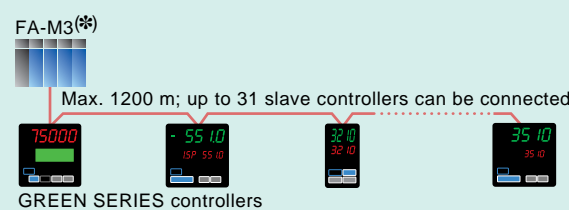

## Coordinated Operation

In coordinated operation, a UP program controller or UT digital indicating controller is used as a master controller and multiple UT digital indicating controllers as slave controllers. The slave controllers are operated in accordance with the actions of the master controller.

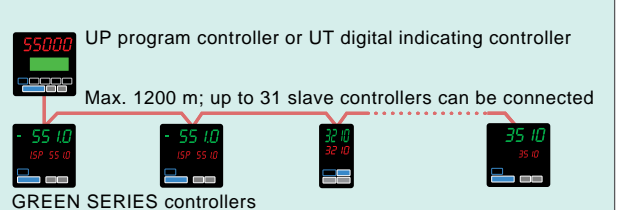

# 48x48(1/16DIN) Controllers

## UT130/UT150/UP150



UT130/150 and UP150 Specification Table

	UT130	UT150	UP150
PV/SP Data display	3 digits	4 digits / 4 digits	
PV Input	1 universal input (TCs, RTDs)	1 universal input (TCs, RTDs, mV, V)	
Indication accuracy	±2°C ±1digit for TC ±1°C ±1digit for RTD	±2°C ±1digit for TC ±1°C ±1digit for RTD ±0.3%±1digit for mV/V input	
Control scan period	500ms		
Control loops and mode	1 loop, AUTO mode only		1 loop, RUN/RESET, HOLD/Cancel HOLD
Number of Setpoint (SP)	1	2	NA
Number of Program patterns/segments	NA		1 program pattern/16 segments
Control Algorithm	ON/OFF, Time-proportional PID, Heating & Cooling	ON/OFF, Time-proportional PID, Continuous PID, Heating & Cooling	ON/OFF, Time-proportional PID, Continuous PID
SUPER, Auto tuning	SUPER, Dynamic AT		SUPER
Control Outputs	Select from Relay or Voltage Pulse	Select from Relay, Voltage Pulse or 4 to 20mA	
PV Retransmission Output	Not available (NA)	1 point (4 to 20mA)	
Timer function	NA	Two timers (0 to 99min.59sec)	NA
Program time span	NA		0 second to 1,599 hour
Digital Inputs	NA	2 (sp1/sp2, RUN/STOP, Timer function)	2 (RUN/RESET, HOLD/Cancel HOLD)
Digital Outputs	2 (Alarm or Timer outputs)		2 (PV event and Time event)
RS485 Communication Protocols	Two-wire, MODBUS, PC-link, Ladder		
Approvals	General = UL, CE, CSA Front Protection= IP65		
Other specifications	Size=48*48*100mm, Power supply = 24VAC/DC or 90 to 264V AC, Power consumption=8VA		
Ambient T, Limits RH	0 to 50 , 20 to 90%		

### Model and Suffix Codes

Model	Suffix Code	Description	Notes
UT130	-	Temperature controller	
Output signal (for heating) Note 1	-R	Relay contact output (for time-proportional PID or on/off control)	Note 1: "/AL" cannot be specified when specifying "/HBA".
	-V	Voltage pulse output (for time-proportional PID)	
Output signal (for cooling)	N	No cooling output (Standard type)	Note 2: "/HBA" and "/RS" cannot be specified at the same time when selecting heating/cooling type.
	R	Relay contact output (for time-proportional PID)	
Options	/AL	Alarm outputs (2 points) Note 1	Note 3: Sensor of heater burnout alarm is CTL-6-S or CTL-12-S36-8 (URD Co., Ltd., Japan) To be purchased separately
	/HBA	Heater burnout alarm and 2 other alarm outputs (includes the functions of /AL) Notes 1, 2, 3	
	* /RS	Communication function Note 2	
	/V24	Power Supply 24VDC/24VAC	

Model	Suffix Code	Description	Notes
UT150	-	Temperature controller	
Output signal (for heating) Note 1	-R	Relay contact output (for time-proportional PID or on/off control)	Note 1: "/HBA" can not be specified when selecting "-A:4 to 20mA output".
	-V	Voltage pulse output (for time-proportional PID)	
Output signal (for cooling) Note 1	-A	4 to 20 mA output (for continuous PID) Note 1	Note 2: "/AL" can not be specified when "/HBA" is specified.
	N	No cooling output (Standard type)	
Options	/AL	Alarm outputs (2 points) Note 2	Note 3: "/HBA" and "/RET" cannot be specified at the same time when selecting standard type.
	/HBA	Heater burnout alarm and 2 other alarm outputs (includes the functions of /AL) Notes 1, 2, 3, 6, 7	
	/EX	Switchover between SP1 and SP2, and starting of timer by external contacts Notes 4, 6	Note 4: "/EX" and "/RS" cannot be specified at the same time when selecting standard type.
	/RET	4 to 20 mA retransmission output of measured value (PV) Notes 3, 5	
	* /RS	Communication function Notes 4, 6	Note 5: "/RET" cannot be specified when selecting heating/cooling type.
	/V24	Power Supply 24VDC/24VAC	
			Note 6: "/HBA", "/EX" and "/RS" cannot be specified at the same time when selecting heating / cooling type.
			Note 7: Sensor of heater burnout alarm is CTL-6-S or CTL-12-S36-8 (URD Co., Ltd., Japan) To be purchased separately

Model	Suffix Code	Description	Notes
UP150	-	Program Temperature controller	
Output signal	-R	Relay contact output (for time-proportional PID or on/off control)	Note 1: /RS option and /EX option cannot be specified at the same time.
	-V	Voltage pulse output (for time-proportional PID)	
Fixed code	N	Always N	
	/EX	Two digital inputs for RUN/RESET and HOLD/CANCEL Note 1	
Options	* /RET	4 to 20 mA retransmission output of measured value (PV)	
	/RS	Communication function Notes 1	
	/V24	Power Supply 24VDC/24VAC	

\* When specifying the /RS option, be sure to order the required number of copies of Communication Functions User's Manual separately.

### UT150 Function Block Diagram

Functional block diagram for Heating & Cooling type UT150 controller.

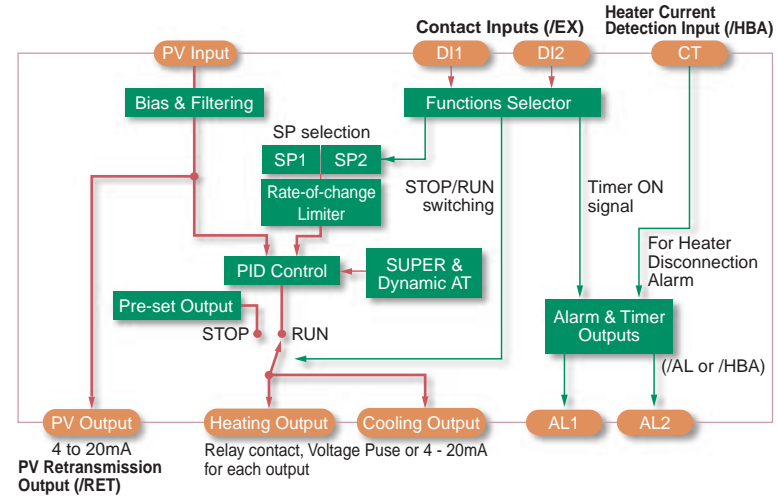

### SUPER Function & Dynamic AT

SUPER control function suppresses overshooting. The field-proven SUPER function utilizes build-in operator experience and Fuzzy theory to deliver fine control and suppress overshooting.

The Dynamic Auto Tune function of the UT130 and UT150 series assures stable control. Whenever you change the setpoint(SP), the function automatically turns the PID parameters and updates them to the suitable setting.

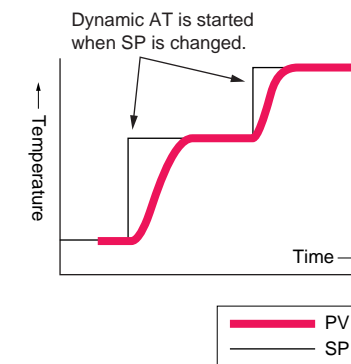
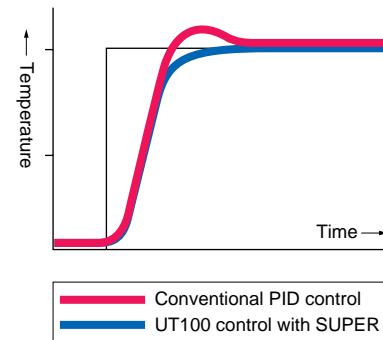

### UP150 Function Block Diagram

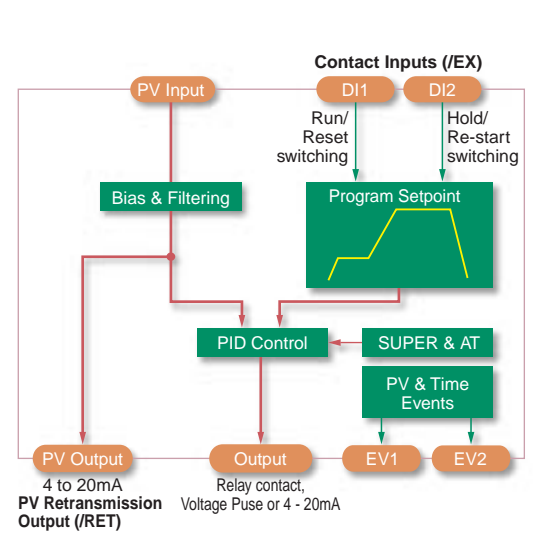

### Temperature Program

Number of program pattern: One  
Accuracy of program time span: +/-2% of span  
Program operations: Wait, Hold, Advance

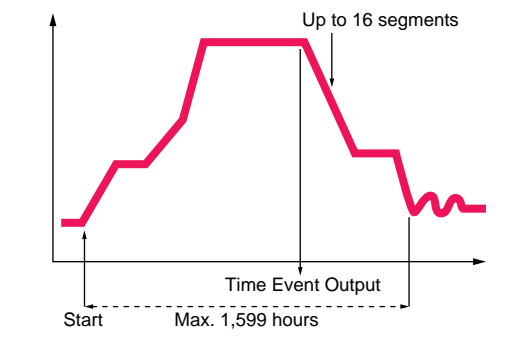

### UT150/Z Motorized Valve Controller

Model UT150/Z has two relay contact outputs to control a motorized valve or a motorized actuator. Model UT150/Z does not need the valve position feedback signal. This controller estimates the valve position automatically.

UT150/Z has MAN mode for moving the valve position manually. Non-linear control function is available to prolong the valve life.

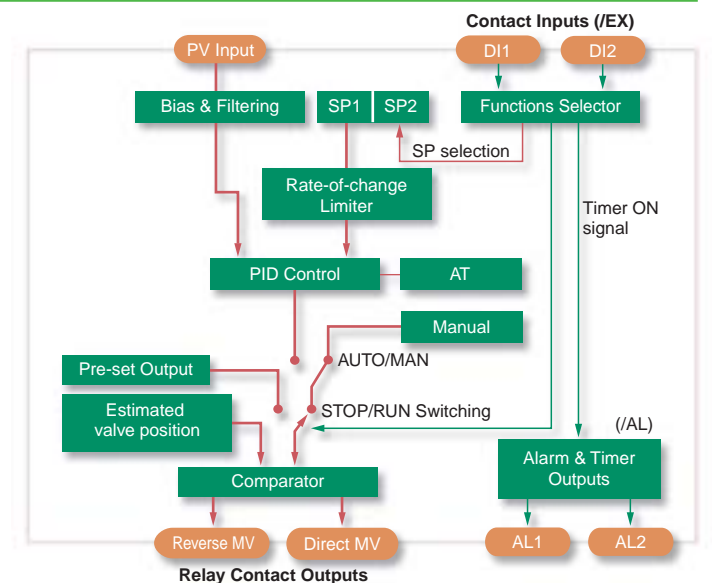
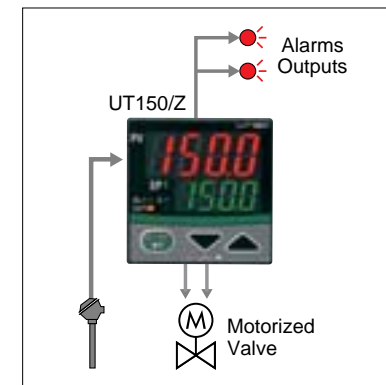

## 48×96(1/8DIN)Controllers

# UT321/UT420/UT520

### Active color PV display:

The color of display automatically switches from Green to Red, or Red to Green.

### Status indicator lamps:

Display alarm status(AL1, 2, 3), manual operation (MAN), and target setpoint No. (SP2, 3, 4)

### Light loader interface:

Communication port for parameter setting by personal computer



### SP display:

Displays target setpoint (SP), control output, valve opening, and parameter settings

## 96×96(1/4DIN)Controllers

# UT351/UT450/UT551

### Active color PV display



UT321/420/520 Specification Table

	UT321	UT420	UT520
<b>PV/SP Data display</b>	4 digits Active Color / 4 digits	5 digits / 5 digits	
<b>PV Input</b>	1 universal input (TCs, RTDs, mV, V)		
<b>Indication accuracy</b>	0.1% ±1digit		
<b>Auxiliary Analog Input</b>	Not Available	1 for remote SP	1 for remote SP or secondary PV
<b>Control scan period</b>	250ms	200ms	50, 100, 200ms
<b>Control loops</b>	1	1	1 or 2 (cascade)
<b>Control modes</b>	MAN/AUTO	MAN/AUTO/CAS, RUN/STOP	
<b>Number of Setpoint(SP)</b>	4	8	
<b>Control Algorithm</b>	ON/OFF, PID (Continuous, Time-proportional), Heating & Cooling.	ON/OFF, 3 position, PID (Continuous, Time-proportional), Heating & Cooling	
<b>SUPER, Auto tuning</b>	SUPER, SUPER2, AT		
<b>Control Outputs(MV)</b>	Select from Relay, Voltage Pulse or 4 to 20mA		
<b>Auxiliary Analog Output (*1) (4 to 20mA)</b>	1 point except for Heating/Cooling control ( Cannot use with LPS15V )	1 point ( Cannot use with LPS15V ) 2 points when MV is relay output	
<b>Loop Power Supply (LPS)</b>	2 points, 15V and 24V(option)	1point, 15V	
<b>Digital Inputs</b>	2	2 or 4	2 or 4
<b>Digital Outputs</b>	3	3	3
<b>RS485 Communication Protocols</b>	Four-wire, MODBUS, PC-link, Ladder or Coordinated Operation.		
<b>Approvals</b>	General = UL, CE, CSA Front Protection = IP55		
<b>Other specifications</b>	Size=48(W)*96(H)*100(D)mm, Power supply =90 to 264V AC, Power consumption=max. 20VA		
<b>Ambient T, Limits RH</b>	0 to 50 °C, 20 to 90%RH		

(\*1) Retransmission is available for PV, SP or MV.

### Model and Suffix Codes

Model	Suffix Code	Description	Note
UT321		Digital indicating controller, with Active color PV display	Note: Sensor of heater burnout alarm is CTL-6-S or CTL-12-S36-8(URD Co.,Ltd., Japan) To be purchased separately
Type	-0	Standard type	
	-2	Heating/cooling type	
	-3	Standard type with 24V DC loop power supply	
Options	0	None	
	1	Communication functions, heater burnout alarm (2 points) Note	
	2	Heater burnout alarm (2 points) Note	

Model	Suffix Code	Description	Contact input/output available	
UT420		Digital indicating controller	Contact input	Contact output
Type	-0	Standard type		
Options	0	None	DI1, DI2	AL1, AL2, AL3
	7	Communication functions, remote input, 2 additional DIs	DI1, DI2, DI3, R/L	AL1, AL2, AL3
	8	Remote input, 2 additional DIs	DI1, DI2, DI3, R/L	AL1, AL2, AL3

Model	Suffix Code	Description	Contact input/output available	
UT520		Digital indicating controller	Contact input	Contact output
Type	-0	Standard type		
Options	0	None	DI1, DI2	DO1, DO2, DO3
	7	Communication functions, auxiliary analog(remote) input, 2 additional DIs	DI1, DI2, DI3, DI8	DO1, DO2, DO3
	8	Auxiliary analog(remote) input, 2 additional DIs	DI1, DI2, DI3, DI8	DO1, DO2, DO3

Model	Suffix Code	Description	Note
UT351		Digital indicating controller, with Active color PV display	Note: Sensor of heater burnout alarm is CTL-6-S or CTL-12-S36-8(URD Co.,Ltd., Japan) To be purchased separately
Type	-0	Standard type	
	-2	Heating/cooling type	
	-3	Standard type with 24V DC loop power supply	
Options	0	None	
	1	Communication functions, heater burnout alarm (2 points) Note	
	2	Heater burnout alarm (2 points) Note	
	A	Ethernet communication*	

\*Ethernet option is not applicable with "-3" standard type with 24V DC loop power supply.

● Model UT320 and UT350 are also available.

UT351/450/551 Specification Table

	UT351	UT450	UT551
<b>PV/SP Data display</b>	4 digits Active Color / 4 digits	5 digits / 5 digits	5 digits Active Color / 5 digits
<b>PV Input</b>	1 universal input (TCs, RTDs, mV, V)		
<b>Indication accuracy</b>	0.1% ±1digit		
<b>Auxiliary Analog Input</b>	Not Available	1 for remote SP	1 for remote SP or secondary PV
<b>Control scan period</b>	250ms	200ms	50, 100, 200ms
<b>Control loops</b>	1	1	1 or 2 (cascade)
<b>Control modes</b>	MAN/AUTO	MAN/AUTO/CAS, RUN/STOP	
<b>Number of Setpoint(SP)</b>	4	8	
<b>Control Algorithm</b>	ON/OFF, Time-proportional PID, Continuous PID, Heating & Cooling	ON/OFF, 3 position, Time-proportional PID, Continuous PID, Heating & Cooling	
<b>SUPER, Auto tuning</b>	SUPER, SUPER2, AT		
<b>Control Outputs(MV)</b>	Select from Relay, Voltage Pulse or 4 to 20mA		
<b>Auxiliary Analog Output (4 to 20mA)</b>	1 point except for Heating/Cooling control ( Cannot use with LPS15V )	1 point ( Cannot use with LPS15V ) 2 points when MV is relay output	
<b>Loop Power Supply (LPS)</b>	2 points, 15V and 24V(option)		
<b>Digital Inputs</b>	2	2, 3, 6 or 7	2, 3, 7 or 8
<b>Digital Outputs</b>	3	3 or 4	3 or 7
<b>Industrial Ethernet</b>	Available	Not Available	Not Available
<b>RS485 Communication Protocols</b>	Four-wire, Protocol is MODBUS, PC-link, Ladder or Coordinated Operation.		
<b>Approvals</b>	General = UL, CE, CSA Front Protection = IP55		
<b>Other specifications</b>	Size=96(W)*96(H)*100(D)mm, Power supply =90 to 264V AC, Power consumption=max. 20VA		
<b>Ambient T, Limits RH</b>	0 to 50 °C, 20 to 90%RH		

### Model and Suffix Codes

Model	Suffix Code	Description	Contact input/output available	
UT450		Digital indicating controller	Contact input	Contact output
Type	-0	Standard type		
	-1	Position-proportional type		
	-2	Heating/cooling type		
	-3	Standard type with 24V DC loop power supply		
Options	-4	Position-proportional type with 24V DC loop power supply		
	0	None	DI1, DI2	AL1, AL2, AL3
	1	Communication functions, remote input, 5 additional DIs, 1 additional Alarm	DI1 to DI6, R/L	AL1 to AL4
	2	Communication functions, remote input, 1 additional DI	DI1, DI2, R/L	AL1, AL2, AL3
	3	4 additional DIs, 1 additional Alarm	DI1 to DI6	AL1 to AL4
	4	Remote input, 1 additional DI	DI1, DI2, R/L	AL1, AL2, AL3

Model	Suffix Code	Description	Contact input/output available	
UT551		Digital indicating controller	Contact input	Contact output
Type	-0	Standard type		
	-1	Position-proportional type		
	-2	Heating/cooling type		
	-3	Standard type with 24V DC loop power supply		
Options	-4	Position-proportional type with 24V DC loop power supply		
	0	None	DI1, DI2	DO1, DO2, DO3
	1	Communication functions, auxiliary analog(remote) input, 6 additional DIs, 4 additional DOs	DI1 to DI8	DO1 to DO7
	2	Communication functions, auxiliary analog(remote) input, 1 additional DI	DI1, DI2, DI8	DO1, DO2, DO3
	3	5 additional DIs, 4 additional DOs	DI1 to DI7	DO1 to DO7
	4	Auxiliary analog(remote) input, 1 additional DI	DI1, DI2, DI8	DO1, DO2, DO3
	A	With Ethernet communication function	DI1, DI2	DO1, DO2, DO3
	B	With Ethernet communication function, auxiliary analog (remote) input. And 1 additional DI	DI1, DI2, DI8	DO1, DO2, DO3
	C	With Ethernet communication function, 5 additional DIs AND 4 additional DOs	DI1 to DI7	DO1 to DO7
	D	With Ethernet communication function, auxiliary analog (remote) input, 6 additional DIs and 4 additional DOs	DI1 to DI8	DO1 to DO7

● Model UT550 are also available.

# Excellent Control, Multifunction Controllers

## UT750/US1000

**Status indicator lamps:**  
Display loop-2 PV(PV 2), deviation status (▲, ▬, ▼), alarm status (AL 1, 2, 3, 4), cascade operation (CAS), remote operation (REM1, REM2), manual operation (MAN1, MAN2), and operation stop (STP)

**Light loader interface:**  
Communication port for parameter setting by personal computer and custom computation downloading

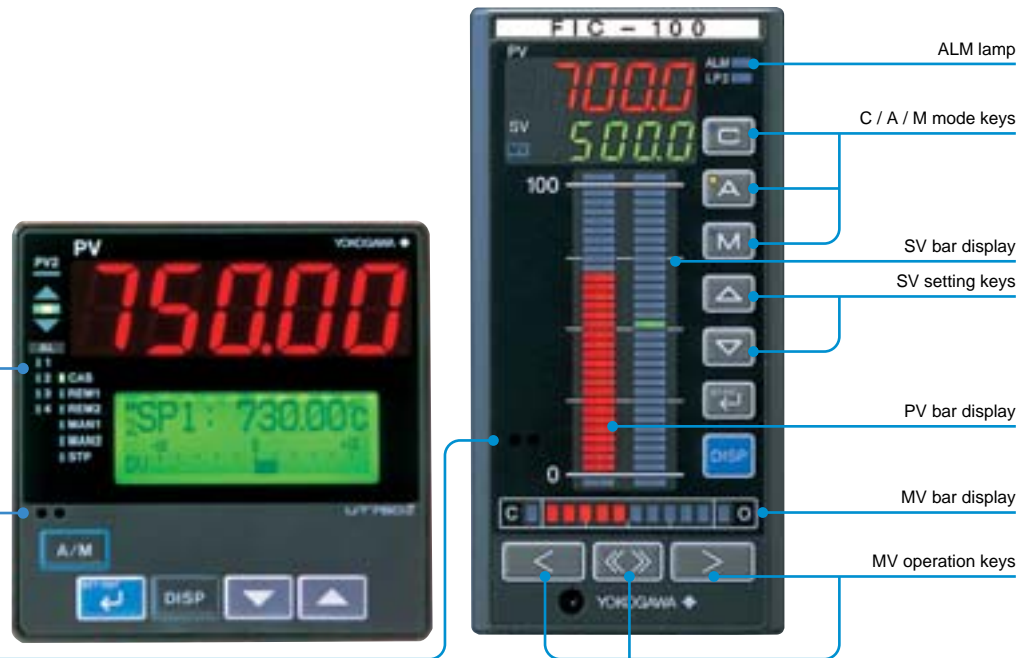

### UT750, US1000 Specification Table

	UT750	US1000
PV/SP Data display	5 digits / 5 digits with LCD display	5 digits / 5 digits with Bar Graphs
PV Inputs	2 universal inputs (TCs, RTDs, mV, V)	
Indication accuracy	0.1% ±1digit	
Auxiliary Analog Input	1 point	
Control scan period	50, 100, 200, 500ms	
Control loops	1 or 2(cascade, dual)	
Number of Setpoint (SP)	8	
Control Algorithm	ON/OFF, 3 position, PID (Continuous, Time-proportional), Heating & Cooling, Position-proportional PID	
SUPER, Auto tuning	SUPER, SUPER2, AT	SUPER, AT
Custom Computation	Standard	Option
Control Outputs (MV)	Select from 2 sets of Relays, Voltage Pulses or 4 to 20mA	
Auxiliary Analog Output (4 to 20mA)	1 point, 2 points when MV is relay output	
Loop Power Supply	1 point of 15V ( Cannot use with auxiliary analog output )	2 points of 24V
Digital Inputs	2 or 7	
Digital Outputs	3 or 7	
RS485 Communication Protocol	MODBUS, PC-link, Ladder, Coordinated Operation	MODBUS, PC-link
Front Protection	IP55	IP65
General Approvals	UL, CE, CSA	CE, CSA, FM-non incandive
Power Supply, Consumption	90 to 264 V AC, max. 20VA	90 to 264 V AC, max. 25VA
Size, weight	96(W)*96(H)*100(D)mm, 1kg	72(W)*144(H)*149(D)mm, 0.8kg
Ambient T, Limits RH	0 to 50 °C, 20 to 90%RH	

### Model and Suffix Codes

Model	Suffix Code	Description	Contact input/output available	
UT750		Digital indicating controller		
	-0	Single-loop type	Contact input	Contact output
	-1	Position-proportional type		
	-5	Dual-loop type		
Options	0	None	DI1 to DI7	DO1 to DO7
	1	Communication functions, auxiliary analog(remote) input	DI1 to DI7	DO1 to DO7

Model	Suffix Codes	Description	Analog input		Analog output		Contact			
US1000		Process controller	Universal	Voltage	*LPS	Current/Voltage	Relay	Input	Output	
	Type	-00	Basic type	1	1	1	1	0	2	3
		-11	Enhanced type(with custom computation)	2	1	2	2	1	2	7
		-21	Position-proportional type(with custom computation)	2	1	2	1	1	*2	7
Options	/A10	RS485 communication								

\*LPS:Loop power supply for transmitter.

\*The two contact points in the US1000-21 relay item are the relay output and feedback input.

## Custom Computation for Sophisticated Control

Custom computation allows simple operation sequences and signal computations specific to the application to be specified, which the standard controller mode cannot deal with. Input/output-related computations can be customized using 65 types of computation modules including arithmetical four-rule operations, logical operations, special calculations, etc.

### Controllers Equip Custom Computation

Model UT750 Indicating Controller  
 Model US1000 Process Controller, except US1000-00  
 Model UP750 Program Controller

### Block Diagram of Custom Computation

The custom computation is executed in INPUT Block and OUTPUT Block.  
 Max.number of custom computation modules:  
 UT750,UP750 50 modules for each Block  
 US1000 30 modules for each Block

### Computation Modules

Addition / subtraction / multiplication / division, Processing absolute value / reciprocal, Selecting maximum / minimum / average, Keeping maximum / minimum value, Keeping value, Rate of change limiter, Switch, Limiter, Constant, AND, OR, Exclusive OR, NOT, Latch, Comparison (=, <, >, ≤, ≥), Not equivalent, Within range, Sum, Timer, Ten-segment linearizer, Curve linearizer, Ratio, First order lag filter, Selection of PV from two inputs, Temperature and humidity calculation, Parameter setting.

### Custom Display Function

Data displayed on front panel, can be configured by using Custom Display Configuration Function.

### Applications

#### Temperature & Pressure Compensation for Gas Flow

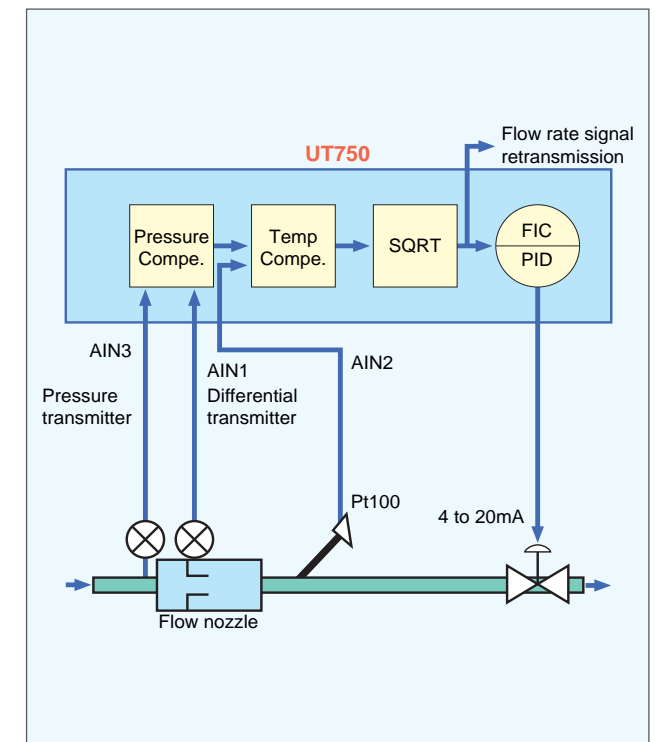

#### Boiler Combustion Control

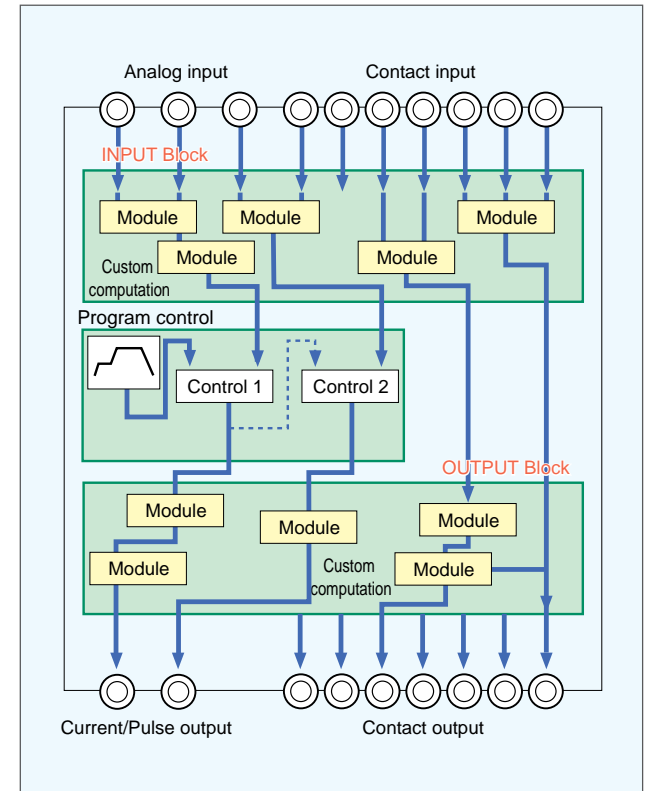
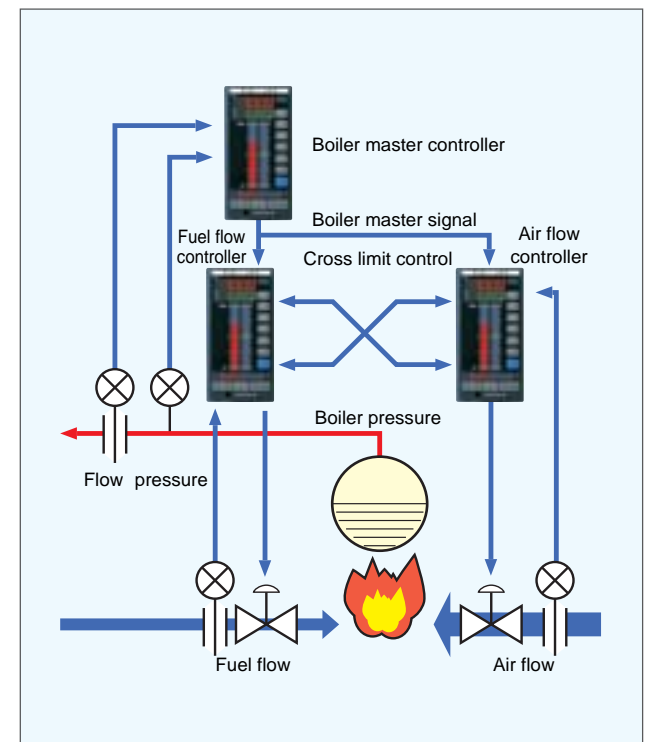

Example for UP750

## 96×96(1/4DIN) Program Controllers

# UP351/UP550/UP750

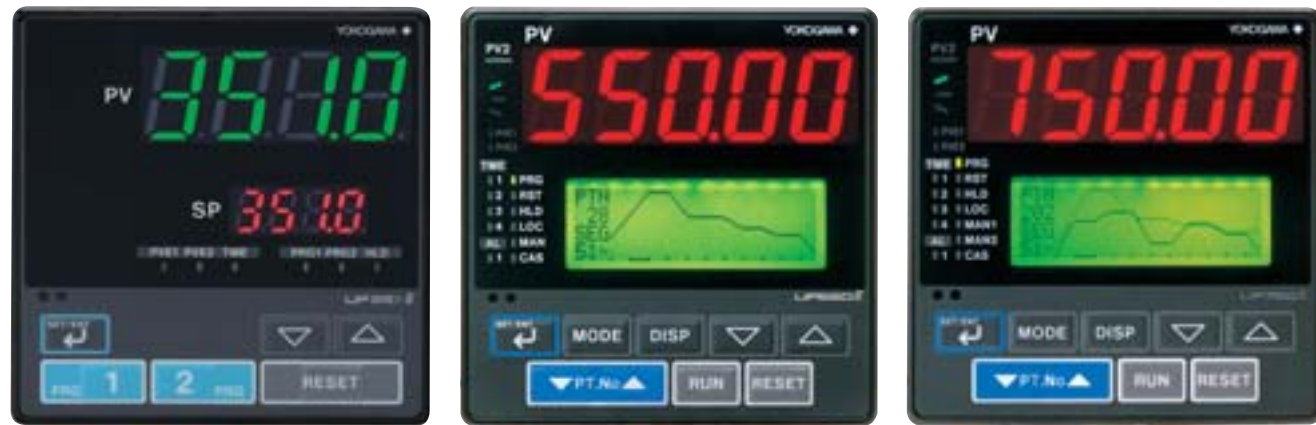

Active Display

UP351/550/750 Specification Table

	UP351	UP550	UP750
PV/SP Data display	4 digits Active Color / 4 digits	5 digits / 5 digits with LCD display	
PV Input	1 universal input (TCs, RTDs, mV, V)		2 universal inputs(TCs, RTDs, mV, V)
Indication accuracy	0.1% ± 1digit		
Auxiliary Analog Input	Not Available (NA)		1 for secondary PV
Control scan period	250ms	100, 200ms	100, 200, 500ms
Control loops	1	1 or 2(cascade)	1 or 2(cascade, dual)
Control modes	PRG/RESET, HOLD, ADVANCE		PRG/RESET, LOCAL, HOLD, ADVANCE
Number of Program Patterns	2	30	300
Number of Segments/ Pattern	10	99	
Number of total Segments	20	300	3,000
Number of PID set	4	8	
Control Algorithm	ON/OFF, PID(Continuous, Time-proportional)	ON/OFF, 3 position, PID(Continuous, Time -proportional), Heating & Cooling, Position-proportional PID	ON/OFF, 3 position, PID(Continuous, Time-proportional), Heating & Cooling
SUPER, Auto tuning	SUPER, SUPER2, AT		
Custom Computation	NA		Standard
Control Outputs (MV)	Select from Relay, Voltage Pulse or 4 to 20mA		
Auxiliary Analog Output (4 to 20mA)	1 point	1 point, 2 points when MV is relay output	
Loop Power Supply (LPS)	1 point, 15V ( Cannot use with auxiliary analog output )		
Digital Inputs	2	7 or 8	7
Digital Outputs	3	7	7
RS485 Communication Protocol	Four-wire, half-duplex Protocol is MODBUS, PC-link, Ladder or Coordinated Operation.		
Approvals	General = UL, CE, CSA Front Protection = IP55		
Other specifications	Size=96(W)*96(H)*100(D)mm, Power supply =90 to 264V AC, Power consumption=max. 20VA		
Ambient T, Limits RH	0 to 50 °C, 20 to 90%RH		

### Model and Suffix Codes

Model	Suffix Code	Description
UP351		Program controller, with Active color PV display
Type	-0	Standard type
Options	0	None
	1	Communication functions

Model	Suffix Code	Description	Contact input/output available	
UP550		Program controller	Contact input	Contact output
Type	-0	Standard type		
	-1	Position-proportional type		
	-2	Heating/cooling type		
Options	0	None	DI1 to DI7	DO1 to DO7
	1	Communication functions, auxiliary analog input, 1 additional DI	DI1 to DI8	DO1 to DO7

Model	Suffix Code	Description	Contact input/output available	
UP750		Program controller	Contact input	Contact output
Type	-0	Single-loop type		
	-5	Dual-loop type		
Options	0	None	DI1 to DI7	DO1 to DO7
	1	Communication functions, auxiliary analog input	DI1 to DI7	DO1 to DO7

● Model UP350 is also available.

## Digital Indicators with Alarms

# UM331/UM351

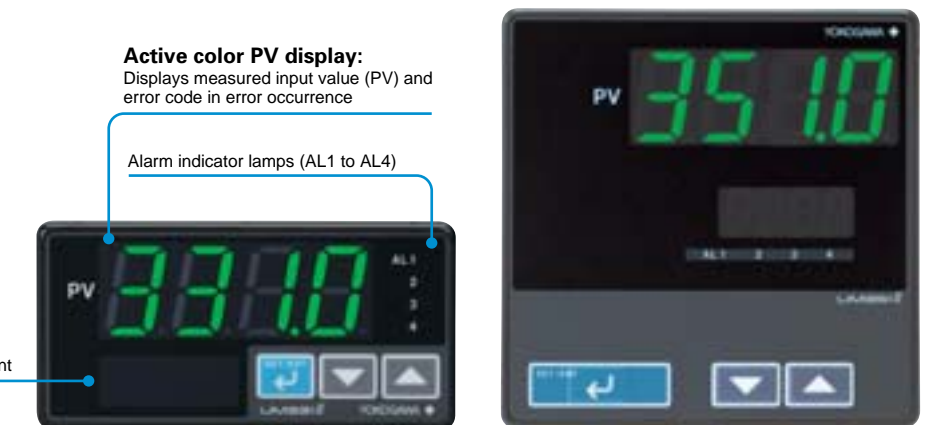

**Active color PV display:**  
Displays measured input value (PV) and error code in error occurrence

Alarm indicator lamps (AL1 to AL4)

**Parameter Setting display:**  
Displays parameter item and setpoint

Active Display

Active Display

UM331/351 Specification Table

	UM331	UM351
PV/Parameter Data display	4 digits Active Color / 4 digits	
PV Input	1 universal input (TCs, RTDs, mV, V)	
Indication accuracy	0.1% ± 1digit	
Control scan period	250ms	
Analog Output (4 to 20mA)	1 point ( Cannot use with LPS15V )	
Loop Power Supply (LPS)	2 points, 15V and 24V(option)	
Digital Inputs	1	
Digital Alarm Outputs	3	
RS485 Communication Protocols	Four-wire, MODBUS, PC-link, Ladder	
Approvals	General = UL, CE, CSA Front Protection = IP55	
Power Supply, Consumption	90 to 264 V AC, max. 20VA	
Size, weight	96(W)*48(H)*100(D)mm, 1kg	96(W)*96(H)*100(D)mm, 1kg
Ambient T, Limits RH	0 to 50 °C, 20 to 90%RH	

### Model and Suffix Codes

Model	Suffix Code	Description
UM331		Digital indicator with alarms, and with Active color PV display
Type	-0	Standard type
	-3	Standard type with 24V DC loop power supply
Options	0	None
	1	Communication functions, 1 additional alarm
	2	1 additional alarm

Model	Suffix Code	Description
UM351		Digital indicator with alarms, and with Active color PV display
Type	-0	Standard type
	-3	Standard type with 24V DC loop power supply
Options	0	None
	1	Communication functions, 1 additional alarm
	2	1 additional alarm

● Models UM330 and UM350 are also available.

# Light Loader Enabling Exceptionally Simple Setting

## LL100/LL200 LL1100/LL1200 for US1000 only

Via Ethernet Communication Connector

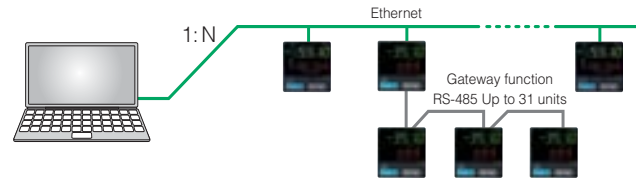

Via RS-485 Communication Terminals

ML2 recommended for RS-232C/RS-485 communication



Via Dedicated Adapter

Can be used while attached to the control panel.

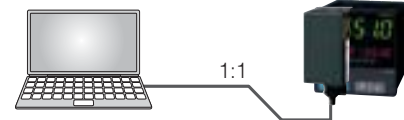

## LL100/LL1100 PC-based Parameters Setting Tool

### Parameter setting functions

Parameters that determine controller functions can easily be set: controller model type, controller mode (single-loop control, cascade control, loop control with PV switching, etc.), universal input/output functions, setup parameters, program parameters, and others.

#### Program Pattern Setting Display(LL100)



### Multi-Monitoring Functions

Measured values (PV), setting values (SP), and control output values (OUT) are displayed as trends (online display). Colors can be applied to trends as desired.

Just connect an instrument: the software detects the model automatically (up to 16 loops). Dedicated adapter/RS-485 Communication/ Ethernet Communication.

#### Multi-monitor Display



### Tuning function

Used to tune a controller's PID parameters. Displays measured input value, target setpoint, and control output value as a trend graph on a personal computer screen, allowing PID parameter modification, AUTO/MAN switching, control output modification in manual operation, etc.

#### Tuning display(LL100)



## LL200/LL1200 PC-based Custom Computation Building Tool

### Custom computation functions

You can create custom computations by combining computation modules.

#### Module connection display(LL200)

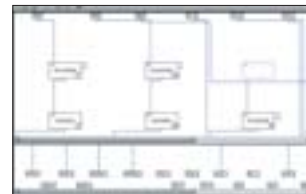

#### Model and Suffix Codes

Model	Suffix code	Description
LL100		LL100 PC-based parameters setting tool, except for UM330/350, UM331/351, US1000, UT100 Series
LL200		LL200 PC-based custom computation building tool (LL100 functions are included), for UT750, UP750
	- E10	English version (for Windows 98/2000 (Professional)/XP (Home Edition/Professional) and NT4.0)

Model	Suffix code	Description
LL1100		LL1100 PC-based parameters setting tool, for US1000
LL1200		LL1200 PC-based custom computation building tool (LL1100 functions are included), for US1000
	- E10	English version (for Windows 95/98/2000 (Professional)/XP (Home Edition/Professional) and NT4.0)

## UD310/UD320/UD350 Manual Setting

The UD300 series manual setters have PV display, and transmit 4 to 20mA DC by manual operation. It can be used as a remote setter for digital indicating controllers like GREEN series controllers.

The SP (target setpoint) will be output in 3 seconds after the change.

The TC, RTD or Voltage input is possible as PV input. When the PV display is not necessary, it can be disappeared.

The two alarm outputs and a PV retransmission output are provided as standard.

The front panel has a splash-proof and dust-proof design



#### Specifications

PV / SP display	4-digit PV / 4-digit SP	
Input type	Universal inputs	
	Thermocouple	K, J, T, E, R, S, B, N, L, U, Platinel 2
	RTD	Pt100, JPt100
Input accuracy	Voltage(mV, V)	0 to 100mV, 0 to 5V, 1 to 5V, 0 to 10V
	Thermocouple	±2°C±1digit
	RTD	±1°C±1digit
	Voltage(mV, V)	±0.3°C±1digit
Sampling period for PV	500ms	
Number of manual setpoint (SP)	1	
Manual setting output	4 to 20mA DC	
PV Retransmission output, can be scaled	4 to 20mA DC	
Alarm output	Number of outputs	2 relay contact, COM terminal is common
	Types	22 types
Power supply	100 to 240 VAC or 24VAC/DC(option)	
Safety and EMC standard	CSA, CE and UL	
Construction (from protection)	IP65 (UD310), IP55(UD320/UD350)	
Dimensions and weight	UD310	48(W)×48(H)×100(depth from panel face)mm, approx. 200g
	UD320	48(W)×96(H)×100(depth from panel face)mm, approx. 300g
	UD330	96(W)×96(H)×100(depth from panel face)mm, approx. 400g

#### Model and Suffix Codes

Model	Suffix code	Description
UD310		UD310 Manual Setter: 4 to 20 mA DC output (48 × 48 × 100 mm)
UD320		UD320 Manual Setter: 4 to 20 mA DC output (48 × 96 × 100 mm)
UD350		UD350 Manual Setter: 4 to 20 mA DC output (96 × 96 × 100 mm)
Fixed code	-0	Always 0
Fixed code	0	Always 0
Option	/V24	Power Supply 24V DC / 24V AC

2 Alarm outputs and PV retransmission output in 4 to 20 mA built in as standard

## Related Instruments

### UT150L/350L Limit Controller

The UT150L and UT350L are an FM approved limit controllers that can be configured either as a high limit or a low limit controller by a user. The limit controllers feature universal input, two alarm outputs, retransmission output, a timer to count the total time the setpoint is exceeded, and a register to retain the maximum temperature reached. The RS485 communication interface is available optionally.

### μR10000 Intelligent Industrial Recorder

μR10000 has carried over μR series high reliability and basic functions. The 101 × 16 full-dot matrix display allows it to monitor various on-site data.

- High reliability and high quality
  - Fully contact-less technology
  - High degree of integration using custom IC
  - Light weight (2.5 kg for 6 dot-model)
  - Dust and splash proof front
- Variety of line-up
  - 1 to 4 pen model, 6 dot model
- Variety of input types
  - Universal inputs
  - Many input sensors available (35 input types such as Pt50, PR20-40 etc)
- Superior ease-of-operation
  - VFD 101 ¥ 16 full dot matrix display
  - Versatile operation display
  - Easily navigable interactive setting
  - New chart cassette
  - White LED
- Analog record of computed result (with computation option:/M1)
- Network function
  - Ethernet, RS422A/485 communication option

#### Specification

Recording width:	100 mm
Chart length:	16 m
Number of inputs	Pen model: 1-4 pens
	Dot model: 6 dot model
Input type:	±20 mV to ±50 V, 1-5 V range
	TC (R, S, B, K, E, J, T, N, W, L, U, WRε)
	RTD (Pt100, Jpt100)
	DC current (with external shunt register)
Measurement interval	Pen model: 125 ms/channel
	Dot model: 1 s/6 dot or 2.5 s/6 dot
Recording method	Pen model: Disposable fel + pen, plotter pen
	Dot model: 6 color wire dot
Recording period	Pen model: consecutive recording
	Dot model: max. 6 channel/10 sec
Display:	VFD 101 ¥ 16 full dot matrix display
Display types	Multiple displays digital, bar, flag, DI/DO display etc can be displayed. 15 display types can be selected from approx. 80 display types.
Alarm levels:	Up to 4 levels for each channel
Alarm type:	High and low limit, differential high and low limit, high and low rate-of-change, delay high and low
Optional specification:	Alarm output, RS422A/485 communication, Ethernet communication, Computation function, Expansion inputs, Remote input etc.
Dimension:	Approx. 144 (W) × 144 (H) × 220 (D) mm
Weight:	2.1 to 2.5 kg





## DAQWORX

DAQWORX is an integrated data acquisition software package that is highly scalable—it will respond flexibly to constant market changes. Combine DAQWORX with Yokogawa recorders, data acquisition stations and units, instrumentation, and measuring instruments to build a user-friendly, PC-based data acquisition system.

With its three classes of software components—Base, Add-on and Gate—DAQWORX will support changes to your system in response to future market demands. Leaving your existing data acquisition system unmodified, you can simply incorporate our recorders, data acquisition units, and high-value-added software to tailor your system for specific needs.

### • Data Acquisition Components

The “Base” software components require neither technical expertise nor programming, enabling you to easily set up hardware and start operating your data acquisition system as soon as possible.

### • High-Value-Added Components

The “Add-on” software components offer advanced functions such as customized windows, monitoring clients, multi-logging, and data acquisition trigger conditioning.

### • Interface Components

The “Gate” software components enable data acquisition using power measuring instruments and Modbus devices in combination with data acquisition units. With these components, you can quickly connect OPC servers and network cameras.

### • DataBrowser

- Easily and quickly search files and display results in waveform
  - Display measured data of different interval and different models on the same time axis
  - Easy data comparison based on the first data or trigger point.

## Software Component

### Data Acquisition Components

- DAQLOGGER: General-purpose medium-speed (1 s max.) data acquisition supports to major data acquisition equipment models
- DAQ32Plus: High-speed (500 ms max.) data acquisition tool for use with DARWIN
- MXLOGGER: Ultra high-speed (10 ms max.) data acquisition tool for use with DAQMASTER
- DAQEXPLORER: Automatic data file acquisition tool for use with DAQSTATION and MobileCorder

### High-Value-Added Components

- AddObserver: Graphical human-machine interface (HMI) for creating monitoring windows for the operator
- AddMulti: Acquires data through groups of channels on a group-by-group basis by combining various measurement conditions
- AddTrigger: Performs advanced data logging using a wide variety of trigger conditions

### DAQLOGGER Client:

Networked remote monitoring client software for DAQLOGGER

### DAQ32Plus Client:

Networked remote monitoring client software for DAQ32Plus

### AddObserver Runtime:

Networked remote monitoring runtime software for AddObserver

### Interface Components

- GateEye: An interface for distributing images from network cameras to DAQObserver
- GateOPC: An interface for data acquisition from OPC servers to DAQLOGGER
- GateWT: An interface for data acquisition from WT-series power meters to DAQLOGGER
- GateDX-P: An interface for data acquisition from DX100P/200P to DAQLOGGER
- GateMODBUS: An interface for data acquisition from MODBUS devices to DAQLOGGER
- GateMX100: An interface for data acquisition from MX100 to DAQLOGGER or Add-on software.
- GateµR: An Interface for data acquisition from µR10000 to DAQLOGGER.
- GateCONTROL: Temperature controller (Green/UT100) and JUXTA(VJ series) can be easily connected to DAQLOGGER.

### <Example for Connection>

- GateModbus is a software interface for connecting devices that support the Modbus protocol with DAQLOGGER data logging software. Allows connection of controllers, power monitors, and signal conditioners to the network (Modbus/TCP) for a small scale instrumentation system that can be set up quickly.
- Reads the input and holding registers from up to 200 channels of various measuring instruments.
- Supports the Ethernet (Modbus/TCP protocols)
- AddObserver monitor design software, an add-on for DAQLOGGER, lets you create the custom monitors that are optimal for your measuring environment.

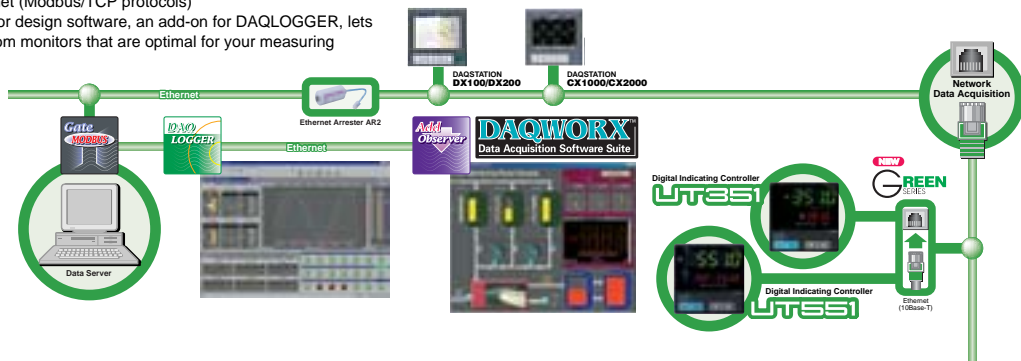

Distribué par :



2 rue René Laennec 51500 Taissy France  
 Fax: 03 26 85 19 08, Tel : 03 26 82 49 29

Email : hvssystem@hvssystem.com  
 Site web : www.hvssystem.com