

BINMASTER

Taking Control... To A Higher Level

SMARTBOB REMOTE UNIT



**INSTALLATION and OPERATING INSTRUCTIONS
PLEASE READ CAREFULLY**

BINMASTER

Division of Garner Industries
7201 No. 98th Street P. O. Box 29709
Lincoln, NE 68507 Lincoln, NE 68529
(402) 434-9102 Fax (402) 434-9133
www.binmaster.com

TABLE OF CONTENTS

SMARTBOB REMOTE UNIT

SPECIFICATIONS - - - - - 3

INTRODUCTION - - - - - 4, 5

INSTALLATION - - - - - 6, 7, 8, 9, 10, 11

TESTING THE REMOTE OPERATION - - - - - 11

AIR PURGE - - - - - 12

WARRANTY AND CUSTOMER SERVICE - - - - - 12

STAINLESS STEEL CABLE REPLACEMENT- - - - - 13, 14, 15

HEATER INSTALLATION INSTRUCTIONS - - - - - 16

PROBE OPTIONS - - - - - 17, 18

LIMITING STAINLESS STEEL CABLE - - - - - 19

MOUNTING TEMPLATE - - - - - 20

SMARTBOB SPECIFICATIONS

Power Requirements:- - - - - 16 VAC 50/60 Hz

Power Consumption: - - - - - 2.1 VA Continuous 2.25 A Intermittent

Current Draw (RMS) - - - - - 0.13 A Continuous 2.25 A Intermittent

Temperature (Operating with Heater):- - - - - -40° F to +185° F (-40° C to +85° C)

Measurement Range:- - - - - 90 ft Standard 150 ft maximum

Measurement Accuracy: - - - - - -0.25%

Repeatability:- - - - - 0.1 ft (0.03m)

Resolution: - - - - - 0.15 inch (0.4 cm)

Communication: - - - - - RS 485 Half Duplex

Wiring Distance: - - - - - 4000 ft (1220m)

Enclosure: SmartBob SBRX - - - - - Type 4X, 5, 7, 9, 12
Explosion Proof Class 1 Group C & D
Class 2 Group E, F, & G

Enclosure: SmartBob SBR - - - - - Type 4, 5, & 12

Mounting: - - - - - 3" NPT floor flange

Conduit Entry: - - - - - 3/4" NPT

Weight:- - - - - -25 lbs.

Diameter - - - - - 9"

Height: - - - - - 14"

Depth: - - - - - 9 1/2"

Air Purge Entry: - - - - - 1/4" NPT

Cable: - - - - - 316 Stainless Steel 0.037" Diameter
Nylon Coated

Options:

Heater with THERmostat: - - - - - 16 VAC, 25.6 VA, 40° F Cycle Temp.

Transformer 150 VA - - - - - -120-240/16 VAC

Transformer 250 VA - - - - - -120-240/16 VAC

1.0 INTRODUCTION

The BinMaster SmartBob is a remote on demand level measurement sensing unit. The SmartBob is available in two Models, the SBR and the SBRX. The SBRX differs from the SBR, only in that it has an explosion proof rated and corrosion protected enclosure. They are designed to work in conjunction with a Personal Computer running Windows 95/98 or NT, a BinMaster SBC console, or a BinMaster RSU (Remote Start Unit). In operation, the SmartBob lowers a weighted Bob to the surface of the product, measuring the distance. A microcontroller counts the pulses from an encoder. Slack in the cable is detected when the Bob reaches the surface, causing the motor to reverse and retract the Bob. The retract distance is also measured for diagnostic purposes to assure that the Bob fully retracts.

General system diagrams showing use with a personal computer, SBC console, and an RSU controller are illustrated in Figures 1a through 1c. Inventory Management System (IMS) Software that runs on Windows 95/98 or NT controls up to 90 SmartBob units from one location. The IMS software also provides current inventory, extended inventory, measuring scheduling, and vendor managed inventory and site status thru faxing and E-mail. The SBC is a stand alone console which can control and display measurements of up to 30 vessels. The RSU controls a single vessel and provides 4-20 mA output for interfacing with other control systems.

PC Based Inventory Management System

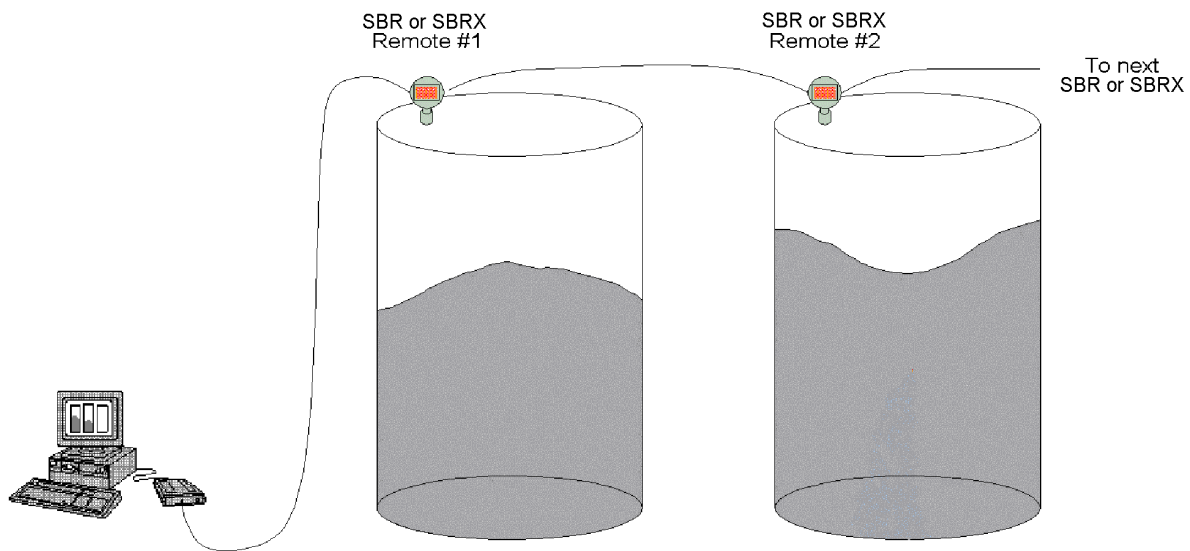

Figure 1a

Console Driven SmartBob System

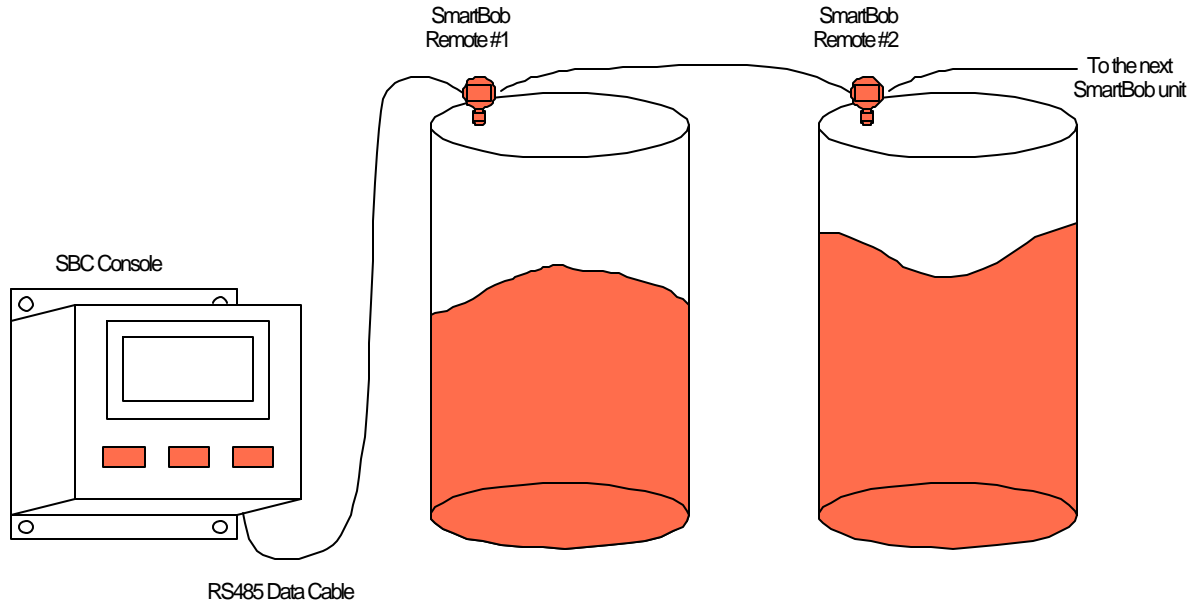

Figure 1b
RSU Controlled System

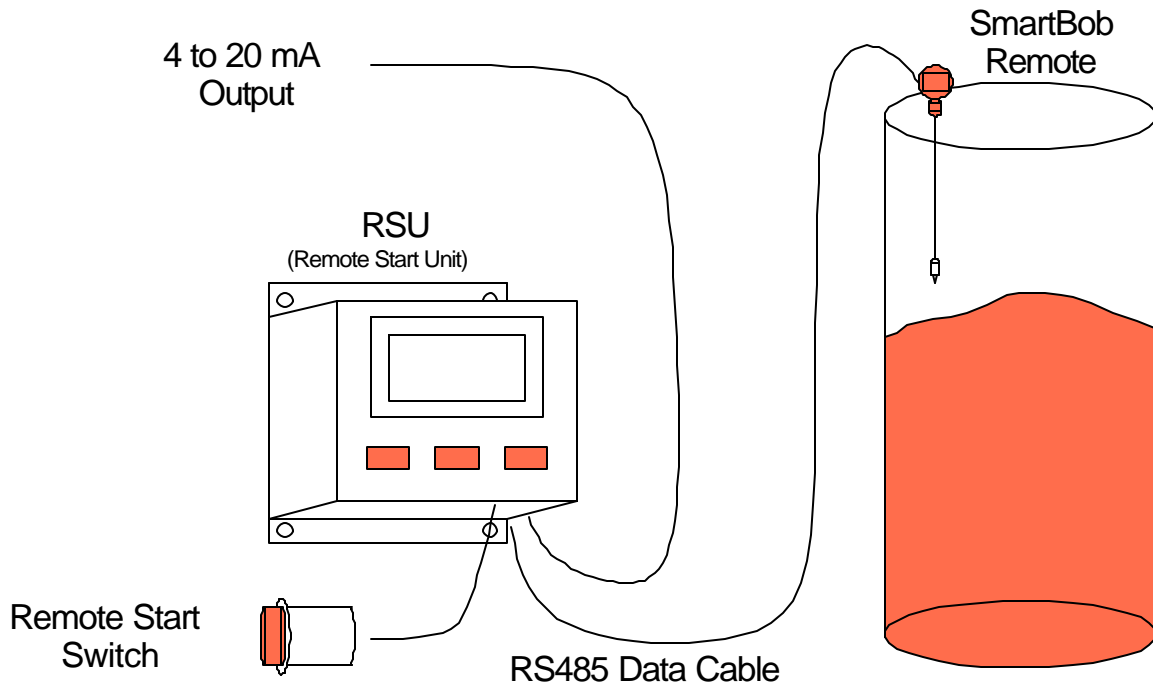
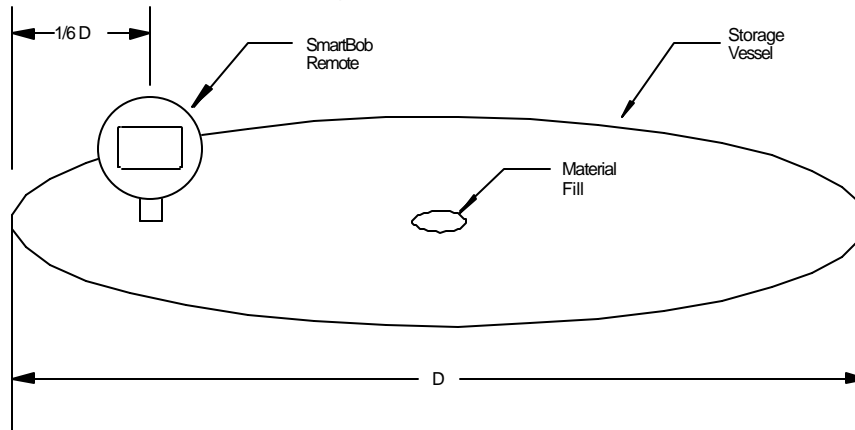

Figure 1c

2.0 INSTALLATION

2.1 LOCATION AND MOUNTING

The SmartBob remote unit is mounted on the top of the storage vessel using a 3 inch NPT coupling. If a 3 inch NPT floor flange is used, it must be on a flat level surface to provide a vertical mount for the unit. For measuring dry solids which involve an angle of repose, it is recommended that the unit be mounted $1/6$ th of the vessel diameter in from the side, see Figure 2. A mounting flange template is provided on page 14 of this manual for a standard 3 inch NPT floor flange with a 5-1/8 inch bolt circle.



2.2 RS485 NETWORK WIRING

The SBR or SBRX remotes are connected by a shielded twisted pair cable referred to as an RS485 network. This cable must run from one remote to the next connecting each remote in a daisy-chained fashion with **no stub branch runs**. All connections should be made at the terminals on the circuit board, see Figure 3 and 4. Be careful to maintain consistent wiring **polarity** at each terminal connection. The shield on the RS485 cable must be connected to the **shield** terminal on the circuit board, not to the enclosure ground.

2.3 NETWORK TERMINATION

On each SBR or SBRX remote unit, SBC, RSU, and RS485 interface module, there is a network termination switch, labeled NTR. The two units on each end of the RS485 daisy-chained network **must** have their NTR switch placed in the "ON" position. All other units on the network must have this switch set to the "OFF" position. See Figures 3 and 4.

2.4 SETTING THE ADDRESS

The BinMaster IMS and SBC console can accommodate up to 30 SmartBob remote units, Therefore a unique address must be set for each remote. Refer to Figure 4 and Table 1 regarding setting the address for remote. This figure and table are also located on the inside cover of the SmartBob enclosure. The RSU console only operates with one SmartBob remote. The address of a remote unit operating with an RSU must be set to #1.

SmartBob Interconnect Wiring Diagram

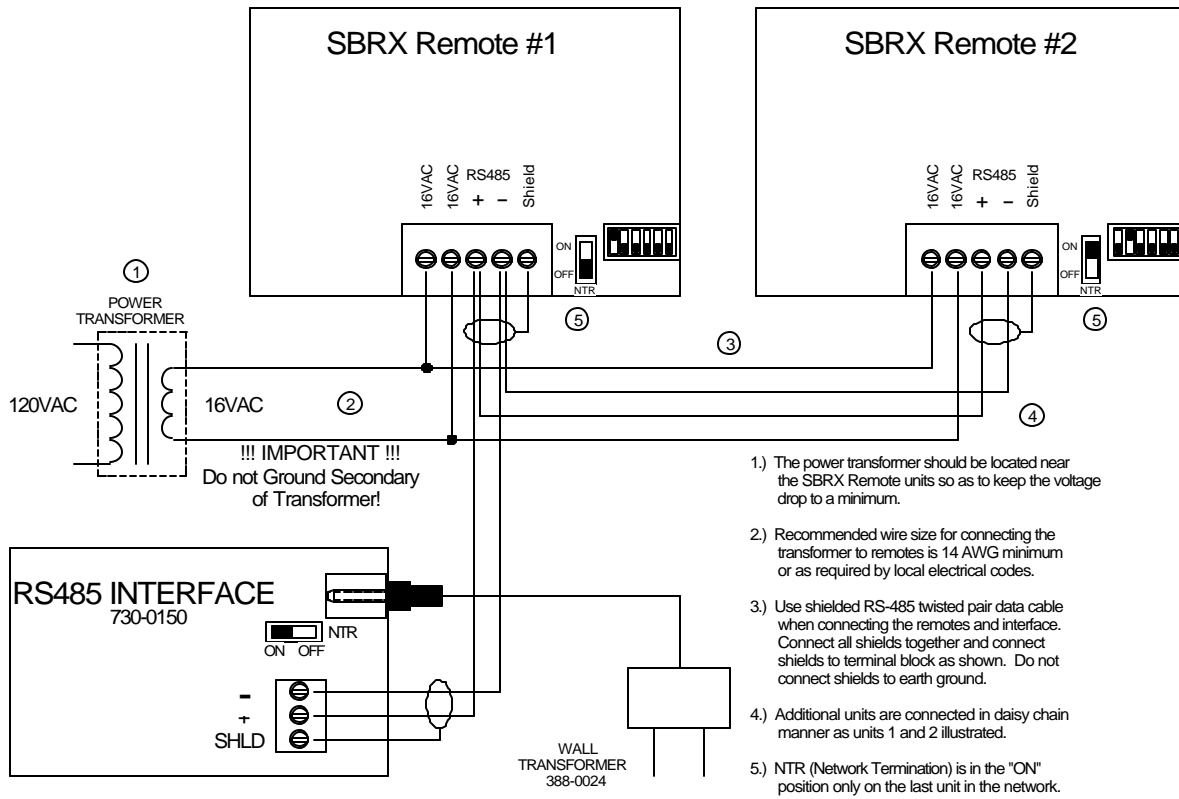

FIGURE 3

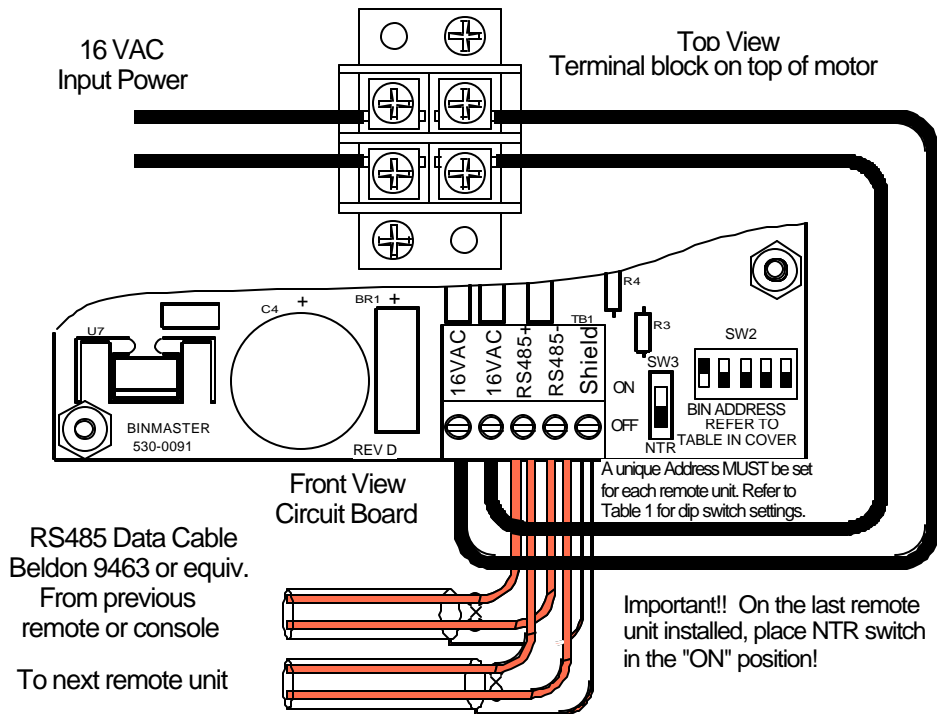

FIGURE 4

BIN ADDRESS	DIP SWITCH SETTING					BIN ADDRESS	DIP SWITCH SETTING				
	1	2	3	4	5		1	2	3	4	5
1	ON	OFF	OFF	OFF	OFF	16	OFF	OFF	OFF	OFF	ON
2	OFF	ON	OFF	OFF	OFF	17	ON	OFF	OFF	OFF	ON
3	ON	ON	OFF	OFF	OFF	18	OFF	ON	OFF	OFF	ON
4	OFF	OFF	ON	OFF	OFF	19	ON	ON	OFF	OFF	ON
5	ON	OFF	ON	OFF	OFF	20	OFF	OFF	ON	OFF	ON
6	OFF	ON	ON	OFF	OFF	21	ON	OFF	ON	OFF	ON
7	ON	ON	ON	OF	OFF	22	OFF	ON	ON	OFF	ON
8	OFF	OFF	OFF	ON	OFF	23	ON	ON	ON	OFF	ON
9	ON	OFF	OFF	ON	OFF	24	OFF	OFF	OFF	ON	ON
10	OFF	ON	OFF	ON	OFF	25	ON	OFF	OFF	ON	ON
11	ON	ON	OFF	ON	OFF	26	OFF	ON	OFF	ON	ON
12	OFF	OFF	ON	ON	OFF	27	ON	ON	OFF	ON	ON
13	ON	OFF	ON	ON	OFF	28	OFF	OFF	ON	ON	ON
14	OFF	ON	ON	ON	OFF	29	ON	OFF	ON	ON	ON
15	ON	ON	ON	ON	OFF	30	OFF	ON	ON	ON	ON

Table 1
Dip Switch Settings for Bin Address

2.5 16 VAC POWER WIRING

Locate the 16 VAC transformer near the SmartBob remote units to keep wire length short and voltage drop to a minimum. All wiring should be installed according to local and/or national codes. The recommended wire size for connection from the transformer to each unit is 12 or 14 AWG depending on the length of the wire. Refer to Figures 3, 4, and 5 for wiring diagrams. The 16 VAC input power connects to the terminal block located above the motor. If the heater option is installed, its wiring may also connect to this terminal AC from the terminal block to the circuit board terminals.

A green ground screw is provided in the SmartBob enclosure for electrically grounding the unit. **Do not** ground the secondary of the 16 VAC transformer. It is recommended that both the power and the RS485 communication cable be ran in metal conduit. If electrical EMI filter should be installed on the primary side of the 16 VAC transformer to reduce interference.

POWER CIRCUIT WIRE DISTANCE FOR SMARTBOB REMOTE UNITS

USING THE 16 VOLT TRANSFORMER P/N 388-0023

WIRE GA.	# OF UNITS, NO HEATERS				# OF UNITS, WITH HEATERS		
	1	2	4	10	1	2	4
16	120	110	100	80	70	50	30
14	190	180	160	130	110	80	50
12	320	300	270	210	190	130	80
Distances given are in Feet							

USING THE 18 VOLT 200 VA TRANSFORMER P/N 388-0034 (530-0132 or 730-0218 pkg option), THE ABOVE DISTANCES CAN BE DOUBLED.

It is important to locate the transformer(s) as close to the SmartBob Remote units as practical. Wiring from the transformer(s) can be done in branch circuit manner so as to minimize the number of units on any one branch. It is preferred that heaters be wired on a separate branch circuit or separate transformer from the SmartBob Remote units.

NOTE: The above distance information is a general guideline only. The exact allowable distance is highly dependent upon the specifics of a given installation. The goal is to maintain at least 14 VAC at the power terminals on the circuit board of each unit during the worst case current draw condition, all heaters ON and a Bob being retracted.

NOTE: ***When installing the SBRX in locations where moisture or moist air could enter the electrical compartment through the electrical conduit, the conduit opening should be adequately sealed with a duct seal compound.***

2.6 TRANSFORMER SIZING

Two sizes of 16 VAC transformers are available from BinMaster, a 150 VA and a 250 VA. The sum of the VA requirements for all the SmartBob Remote units along with the VA requirements of optional heaters, if used, must not exceed the VA rating of the transformer. VA requirements are stated on the Specifications page in the front of this manual. The IMS software and SBC console only allow one SmartBob Remote unit to take a measurement at a time. The VA requirement during measurement is 36 VA. If an installation uses multiple RSU controllers with multiple vessels, care must be taken so as not to take several measurements at the same time and in so doing, overload the transformer.

Transformer Wiring Diagram

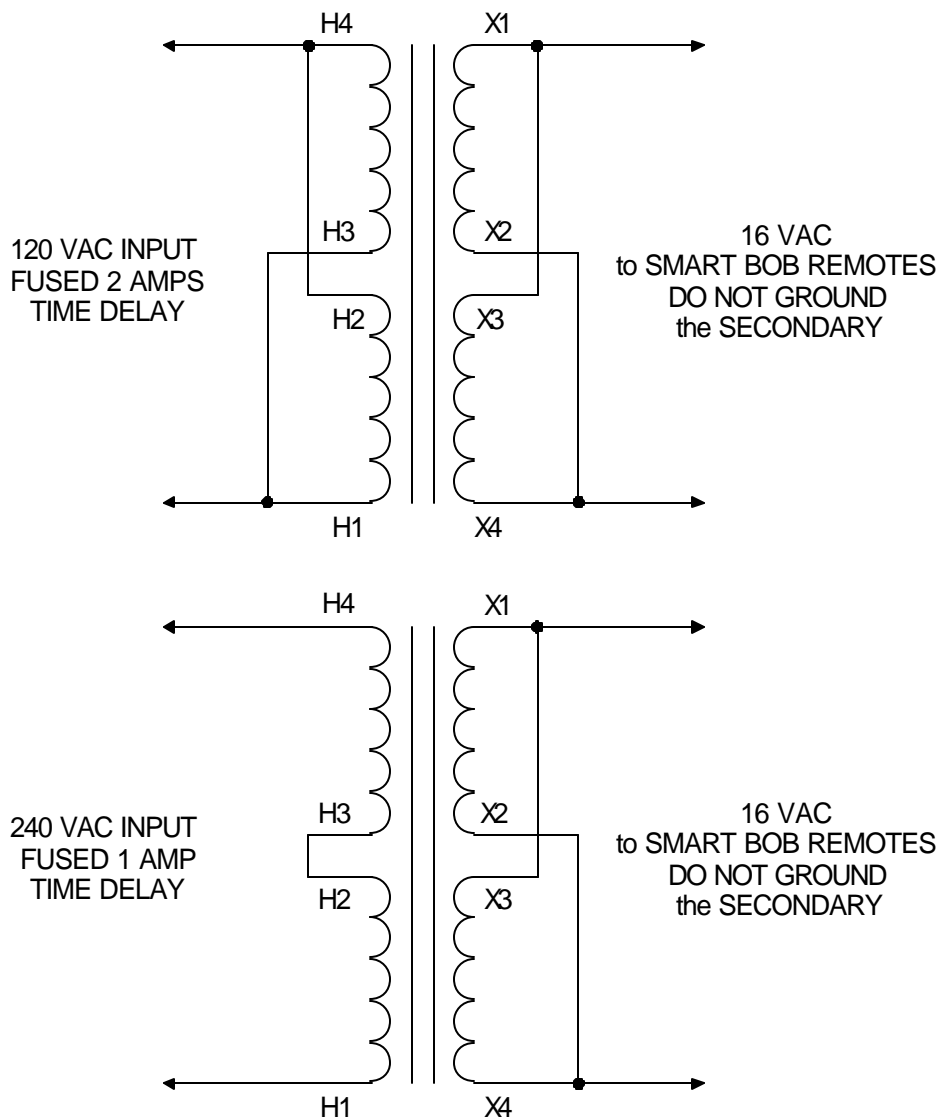

FIGURE 5

2.7 EXTERNAL OVERRIDE

This feature can be used to prohibit measurements during a vessel filling cycle. The IMS software will notify the user that a measurement cannot be taken while a filling operation is in progress. Located on the SmartBob circuit board in the upper right corner, is terminal block TB2. A connection must exist across these terminals for normal operation of the remote unit, see Figure 6. A contact on an external relay can be used to disable the remote unit during a fill cycle to prevent burying the Bob. The use of this feature is optional, if not used, leave the factory installed jumper in TB2.

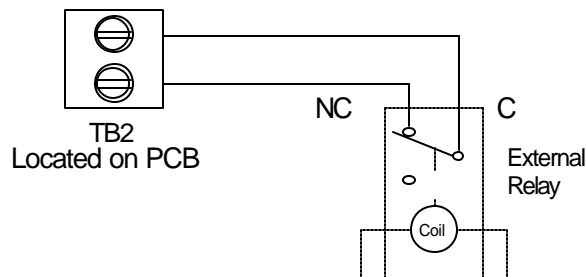

FIGURE 6

3.0 TESTING THE REMOTE OPERATION

IMPORTANT: Complete the **SmartBob INSTALLATION CHECKLIST**, included with this manual, before attempting to operate the units.

3.1 MANUAL OPERATION FROM REMOTE UNIT

Once the SmartBob Remote is installed and wired properly it can be manually cycled to verify proper operation. To perform the manual test:

- Open the electrical side of the remote unit.
- Move MODE switch, located on the upper right side of the circuit board, to the TEST position.
- Press the RESET button located at the top left-hand side of the printed circuit board. The unit will immediately lower the probe Bob to the surface and return.
- Place MODE switch back to the NORMAL position when finished testing.
- Replace the electrical side cover.

3.2 TROUBLESHOOTING

If the remote fails to cycle, verify that the 16 VAC is present at the terminal block and that the RED LED located on the right side of the circuit board, is lighted. This LED should be lighted whenever the 16 VAC is present at the board terminals. If the unit still does not operate, consult the factory at 800 228-4241.

4.0 AIR PURGE SYSTEM

Located on the lower right side of each SmartBob remote unit is a 1/4" NPT air fitting. This fitting can be used to connect an external source of dry, clean air or non-combustible gas to the remote housing. By adding pressure to the remote housing that is slightly greater than that in the vessel, material and dust from the vessel is prevented from entering into the unit. The external pressure should be one (1) psi greater than the ambient pressure in the storage vessel and should be free from moisture and other contaminants.

5.0 WARRANTY AND CUSTOMER SERVICE

5.1 LIMITED WARRANTY

The manufacturer warrants this equipment for two (2) years according to the following terms:

- 1.) This warranty extends to the original purchaser only and commences on the date of original purchase. The original purchaser must mail to the manufacturer the "Warranty Registration" card to confirm the equipment purchase. Failure to do so may void the warranty.
- 2.) The manufacturer will repair or replace any part of this equipment found to be defective, provided such part is delivered prepaid, to the factory. Manufacturer's obligation is limited to the cost of material and labor to repair or replace and does not include transportation expenses.
- 3.) This warranty shall not apply to any product that has, in our judgement, been tampered with, altered, subject to misuse, neglect or accident. In addition, the warranty does not extend to repairs made necessary by normal wear.
- 4.) This warranty is in lieu of all other warranties, expressed or implied.

5.2 CUSTOMER SERVICE

BinMaster offers a toll-free Customer Service phone number, **800 228-4241**. You may call the Customer Service Department for technical and application assistance Monday through Friday from 8:00 AM to 5:00 PM Central Time. International customers call us at **(402) 434-9102** or reach us via **Fax** at **(402) 434-9133**.

Note: This equipment has been tested and found to comply with the limits for a Class A digital device, pursuant to part 15 of the FCC Rules. These limits are designed to provide reasonable protection against harmful interference when the equipment is operated in a commercial environment. This equipment generates, uses, and can radiate radio frequency energy and, if not installed and used in accordance with the instruction manual, may cause harmful interference in which case the user will be required to correct the interference at their own expense.

6.0 STAINLESS STEEL CABLE REPLACEMENT INSTRUCTIONS

1. Disconnect the power source. Remove the flat cover plate on the front of the remote housing.
2. Remove the threaded mount from the bottom of the remote housing.
3. Thread the cable through the threaded mount assembly making sure the cable passes between the wiper brushes.
4. Thread the stainless steel cable around the pulleys as shown in Figure 7 on page 14.
5. Before securing the cable to the pulley, lightly crimp an oval sleeve (Item #3) about 3 or 4 feet from the end of the cable. This sleeve will be the maximum length of cable the unit can release. When the sleeve comes in contact with the idler arm pulley the unit will reverse direction and rewind the cable.
6. Thread the cable through the hole in the spool (Figure 8, on page 15). Thread cable through the ring terminal (Item # 49). Strip 1/8" to 1/4" of the nylon jacket from the stainless steel cable. Secure the cable on the spool by crimping the ring terminal. Secure the ring terminal and spool to the shaft with the nut. This procedure will adequately ground the cable.
7. Reconnect the power source.
8. Pull the cable taut. Cycle the unit, from the computer, console, or by placing the "TEST" position and pressing the reset button. Both the reset button and the "MODE" switch are located on the circuit board. Allow the motor to reverse direction and wind the cable onto the spool. The spool should be turning in a clockwise (CW) direction, with the cable winding over the top. Keep the cable taut until the spool is full and the motor stops. Place the "MODE" switch to the "NORMAL" position, if the "TEST" function was used to cycle the unit.
9. Replace the cover plate.

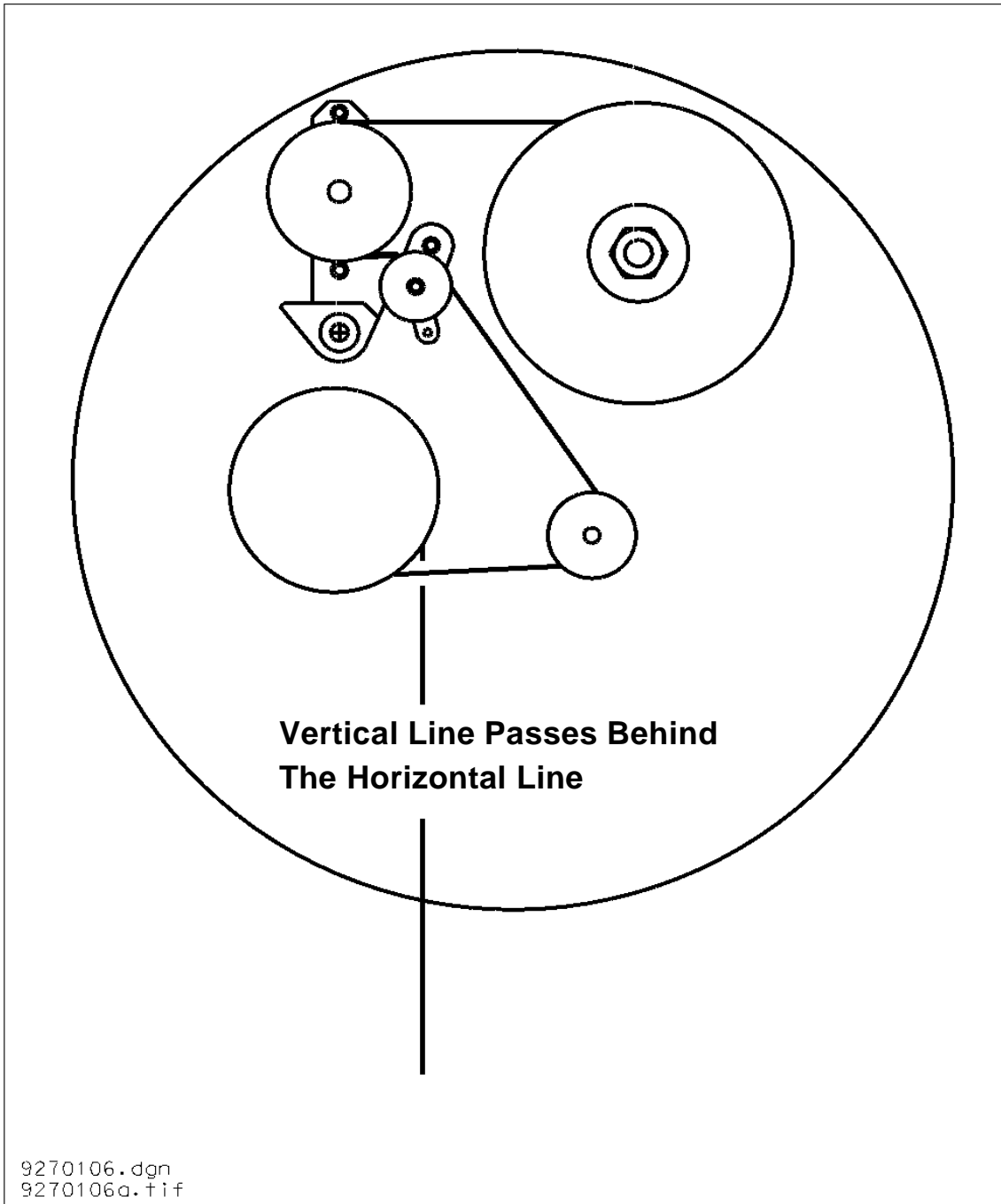
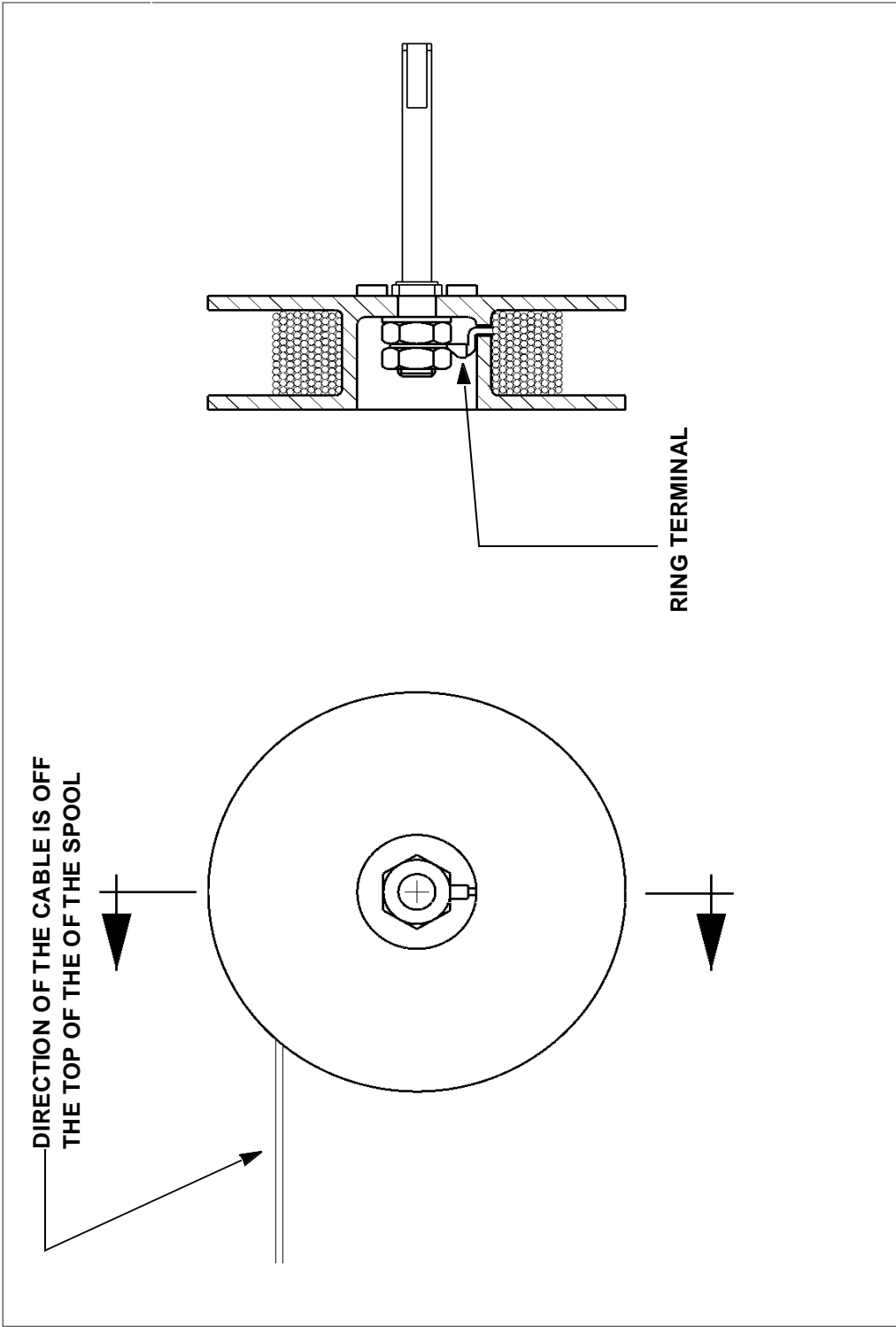

FIGURE 7



9270106.DGN
9270106.TIF

FIGURE 8

7.0 HEATER INSTALLATION INSTRUCTIONS-Optional

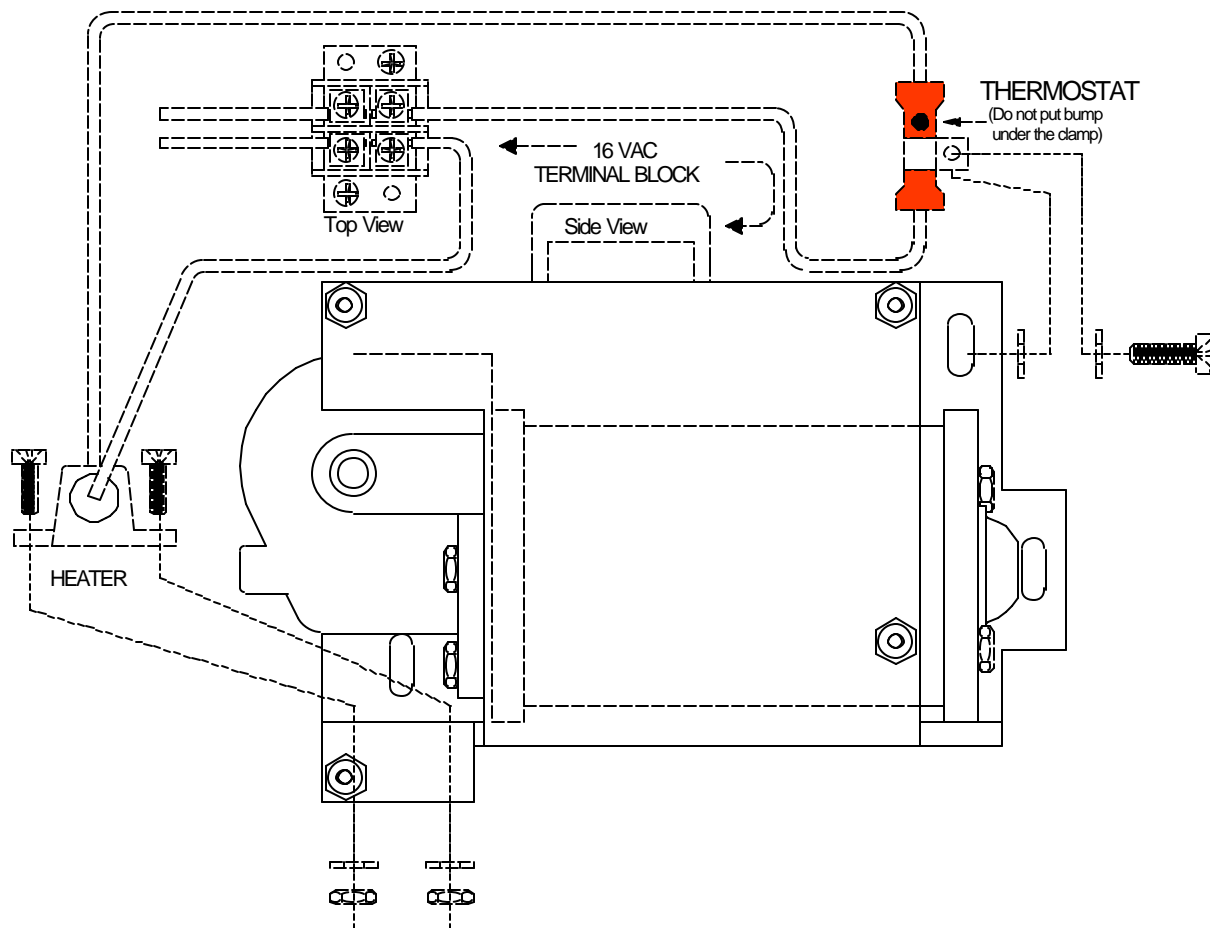

FIGURE 9

1. Remove enclosure cover to access motor side of unit.
2. Locate heater mounting holes below motor gear box.
3. Place heater in position under motor gear box.
4. Insert (2) #4-40 X 1/2" screws through heater and mounting plate.
5. Secure heater using flat washers and hex nuts on the screws.
6. Remove existing screw from upper right-hand corner of the mounting bracket.
7. Secure the thermostat and ring clamp to the mounting bracket with the existing #10 screw and washers. Do not over tighten.
8. Connect wires to 16 VAC circuit. Do not exceed the power rating of your transformer. If possible, connect heaters to a separate 16 VAC heater circuit.

Route the wire away from moving parts.

PROBE OPTIONS



BBP-1

This Polypropylene is designed for granular materials from 20 lbs. per cubic foot and greater.

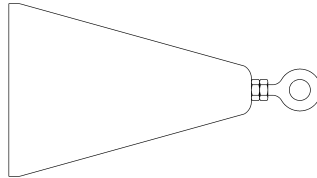

BBP-2

This Bob is a hollow inverted cone made of stainless steel and is designed for bulk products with a density from 5 lbs. to 20 lbs. per cubic foot. This Bob may also be used in liquid applications.



BBP-3

This Bob is designed for granular material with a density from 20 lbs. per cubic foot and greater. The BBP-3 Bob should be filled with a material that is compatible with the material that is stored in the storage bin. Total weight of the Bob when full should be 16 to 20 oz. The BBP-3 Bob is made from an engineering plastic which will not damage the material handling auger, in the unlikely event that the Bob should become separated from the unit.



BBP-4

This submersible Bob is made of 316 stainless steel and was designed to penetrate a liquid measure the solid substance which lies at the bottom of that liquid.

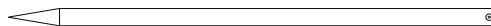

BBP-5

This Bob is made from Delrin and is used in applications that have a steep angle of repose, which without a pointed tip would allow the Bob to slide down the material.

CONE MOUNTING OPTIONS

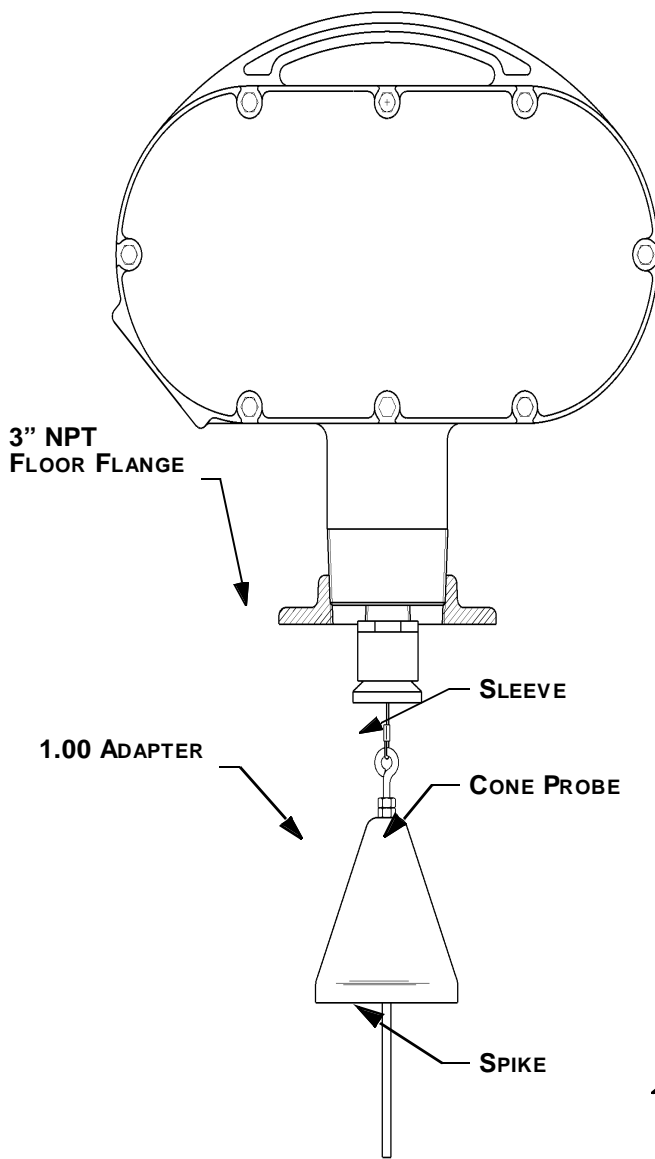

STANDARD FLANGE MOUNT

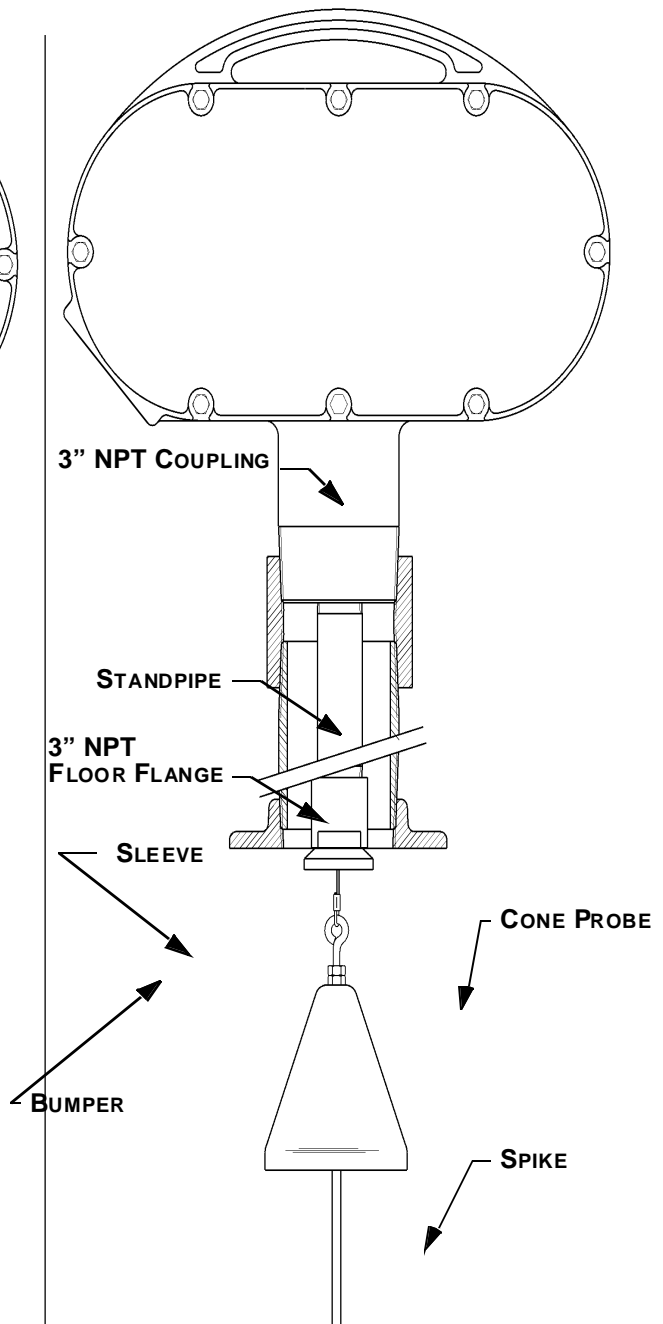

HIGH TEMPERATURE MOUNT

LIMITING STAINLESS STEEL CABLE

It is important to limit the length of cable on the SmartBob Remote, so that the Bob is not lowered into an airlock, screw conveyor, or any other area that the Bob might become trapped in. The SmartBob remote is shipped with 90 feet of cable unless otherwise specified. Disregard these instructions if the unit was ordered with the exact amount of cable necessary for your vessel. This procedure for limiting the cable should be done before the unit is installed:

1. By hand pull all 90 feet of cable out of the unit.
2. Measure from the throat of the SmartBob the height of your vessel or the maximum distance you want the Bob to travel into your vessel.
3. Cut the stainless steel cable at this distance.
4. Thread the stainless steel cable through the plastic cap as shown below.
5. Loop the stainless steel cable through and then back through the extra sleeve provided.
6. Crimp the sleeve around the cable.
7. Test the crimp by pulling on the cap.
8. Screw the Bob on to the plastic cap.
9. Continue installation of the unit on your vessel.

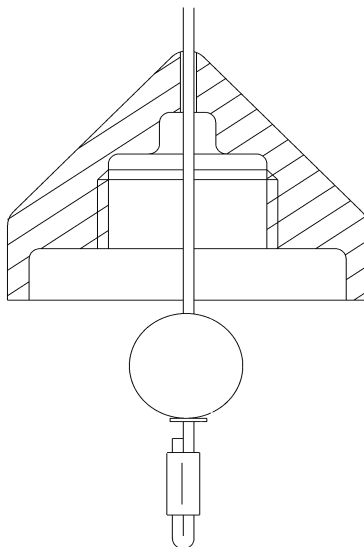

SMARTBOB REMOTE MOUNTING TEMPLATE

